

SERVICE MANUAL CONTENTS

NOTICE

This form lists the contents of the complete Service Manual for this product. The items listed with form numbers are available and included in the manual. If form numbers are listed with mark(*), they are not available for the initial release of the manual. When items are updated, or supplements are added, they will be provided separately.

TITLE	FORM NUMBER
Service Manual Contents	SB4293E00
Safety	SB2003E00
Torque Specifications	SB2004E00
DRIVE & CONTROL SYSTEM	
MicroController Control Systems	SB4294E00
POWER TRAIN	
Power Train	SB4295E00
VEHICLE SYSTEMS	
Vehicle Systems	SB4296E00
Vehicle Systems D & A	SB4297E00
Mast System	SB4298E00
Hydraulic System Schematic	SB4299E00
Electric Systems Schematic	SB4300E00
OPERATION & MAINTENANCE	
Operation & Maintenance Manual	SB2351E00

WARNING

SAFETY

WARNING

The proper and safe lubrication and maintenance for this machine, recommended by DOOSAN, are outlined in the OPERATION & MAINTENANCE GUIDE for this machine.

Improper performance of lubrication or maintenance procedures is dangerous and could result in injury or death. Read and understand the OPERATION & MAINTENANCE GUIDE before performing any lubrication or maintenance.

This serviceman or mechanic may be unfamiliar with many of the systems on this machine. This makes it important to use caution when performing service work. A knowledge of the system and/or components is important before the removal or disassembly of any component.

Because of the size of some of the machine components, the serviceman or mechanic should check the weights noted in this Manual. Use proper lifting procedures when removing any components.

Following is a list of basic precautions that should always be observed.

1. Read and understand all Warning plates and decals on the machine before operating, lubricating or repairing the product.
2. Always wear protective glasses and protective shoes when working around machines. In particular, wear protective glasses when pounding on any part of the machine or its attachments with a hammer or sledge. Use welders gloves, hood/goggles, apron and other protective clothing appropriate to the welding job being performed. Do not wear loose-fitting or torn clothing. Remove all rings from fingers when working on machinery.
3. Do not work on any machine that is supported only by lift jacks or a hoist. Always use blocks or jack stands to support the machine before performing any disassembly.
4. Lower the forks or other implements to the ground before performing any work on the machine. If this cannot be done, make sure the forks or other implements are blocked correctly to prevent them from dropping unexpectedly.

WARNING

Do not operate this machine unless you have read and understand the instructions in the OPERATOR'S GUIDE. Improper machine operation is dangerous and could result in injury or death.

5. Use steps and grab handles (if applicable) when mounting or dismounting a machine. Clean any mud or debris from steps, walkways or work platforms before using. Always face machine when using steps, ladders and walkways. When it is not possible to use the designed access system, provide ladders, scaffolds, or work platforms to perform safe repair operations.
6. To avoid back injury, use a hoist when lifting components which weigh 23 kg (50 lb.) or more. Make sure all chains, hooks, slings, etc., are in good condition and are of the correct capacity. Be sure hooks are positioned correctly. Lifting eyes are not to be side loaded during a lifting operation.
7. To avoid burns, be alert for hot parts on machines which have just been stopped and hot fluids in lines, tubes and compartments.
8. Be careful when removing cover plates. Gradually back off the last two bolts or nuts located at opposite ends of the cover or device and pry cover loose to relieve any spring or other pressure, before removing the last two bolts or nuts completely.
9. Be careful when removing filler caps, breathers and plugs on the machine. Hold a rag over the cap or plug to prevent being sprayed or splashed by liquids under pressure. The danger is even greater if the machine has just been stopped because fluids can be hot.
10. Always use tools that are in good condition and be sure you understand how to use them before performing any service work.
11. Reinstall all fasteners with same part number. Do not use a lesser quality fastener if replacements are necessary. Do not mix metric fasteners with standard nuts and bolts.
12. If possible, make all repairs with the machine parked on a level, hard surface. Block machine so it does not roll while working on or under machine.

WARNING

13. Disconnect battery and discharge any capacitors (electric trucks) before starting to work on machine. Hang "Do Not Operate" tag in the Operator's Compartment.
 14. Repairs, which require welding, should be performed only with the benefit of the appropriate reference information and by personnel adequately trained and knowledgeable in welding procedures. Determine type of metal being welded and select correct welding procedure and electrodes, rods or wire to provide a weld metal strength equivalent at least to that of parent metal.
 15. Do not damage wiring during removal operations. Reinstall the wiring so it is not damaged nor will it be damaged in operation by contacting sharp corners, or by rubbing against some object or hot surface. Do not connect wiring to a line containing fluid.
 16. Be sure all protective devices including guards and shields are properly installed and functioning correctly before starting a repair. If a guard or shield must be removed to perform the repair work, use extra caution.
 17. Always support the mast and carriage to keep carriage or attachments raised when maintenance or repair work is performed, which requires the mast in the raised position.
 18. Loose or damaged fuel, lubricant and hydraulic lines, tubes and hoses can cause fires. Do not bend or strike high pressure lines or install ones which have been bent or damaged. Inspect lines, tubes and hoses carefully. Do not check for leaks with your hands. Pin hole (very small) leaks can result in a high velocity oil stream that will be invisible close to the hose. This oil can penetrate the skin and cause personal injury. Use cardboard or paper to locate pin hole leaks.
 19. Tighten connections to the correct torque. Make sure that all heat shields, clamps and guards are installed correctly to avoid excessive heat, vibration or rubbing against other parts during operation. Shields that protect against oil spray onto hot exhaust components in event of a line, tube or seal failure must be installed correctly.
 20. Relieve all pressure in air, oil or water systems before any lines, fittings or related items are disconnected or removed. Always make sure all raised components are blocked correctly and be alert for possible pressure when disconnecting any device from a system that utilizes pressure.
 21. Do not operate a machine if any rotating part is damaged or contacts any other part during operation. Any high speed rotating component that has been damaged or altered should be checked for balance before reusing.
 22. On LP equipped lift trucks, be sure to close the valve on the LP tank before service work is performed. Always close the valve on the LP tank when the lift truck is being stored. Do not check for LP leaks with an open flame.
 23. Caution should be used to avoid breathing dust that may be generated when handling components containing asbestos fibers. If this dust is inhaled, it can be hazardous to your health. Components in DOOSAN products that may contain asbestos fibers are brake pads, brake band and lining assemblies, clutch plates and some gaskets. The asbestos used in these components is usually bound in a resin or sealed in some way. Normal handling is not hazardous as long as airborne dust which contains asbestos is not generated.
- If dust which may contain asbestos is present, there are several common sense guidelines that should be followed.
- a. Never use compressed air for cleaning.
 - b. Avoid brushing or grinding of asbestos containing materials.
 - c. For clean up, use wet methods or a vacuum equipped with a high efficiency particulate air (HEPA) filter.
 - d. Use exhaust ventilation on permanent machining jobs.
 - e. Wear an approved respirator if there is no other way to control the dust.
 - f. Comply with applicable rules and regulations for the work place (for example in the U.S.A., OSHA requirements as set forth in 29 CFR 1910. 1001).
 - g. Follow environmental rules and regulations for disposal of asbestos.
 - h. Avoid areas where asbestos particles may be in the air.

Specifications

TORQUE SPECIFICATIONS

STANDARD TORQUE FOR INCH FASTENERS

NOTE : Take care to avoid mixing metric and inch dimensioned fasteners. Mismatched or incorrect fasteners can result in vehicle damage or malfunction, or possible injury. Exceptions to these torques are given in the Service Manual where needed.

NOTE : Prior to installation of any hardware, be sure components are in near new condition. Bolt and nut threads must not be worn or damaged. Hardware must be free of rust and corrosion. Clean hardware with a non-corrosive cleaner and apply engine oil to threads and bearing face. If thread lock or other compounds are to be applied, do not apply engine oil.

METRIC NUTS AND BOLTS		
THREAD SIZE (mm)	STANDARD TORQUE	
	(N•m)	(lb•ft)
M6	12 ± 3	9 ± 2
M8	28 ± 7	20 ± 5
M10	55 ± 10	40 ± 7
M12	100 ± 20	75 ± 15
M14	160 ± 30	120 ± 22
M16	240 ± 40	175 ± 30
M20	460 ± 60	340 ± 44
M24	800 ± 100	600 ± 75
M30	1600 ± 200	1200 ± 150
M36	2700 ± 300	2000 ± 225

METRIC TAPERLOCK STUDS		
THREAD SIZE (mm)	STANDARD TORQUE	
	(N•m)	(lb•ft)
M6	8 ± 3	6 ± 2
M8	17 ± 5	13 ± 4
M10	35 ± 5	26 ± 4
M12	65 ± 10	48 ± 7
M16	110 ± 20	80 ± 15
M20	170 ± 30	125 ± 22
M24	400 ± 60	300 ± 45
M30	650 ± 80	480 ± 60
M36	870 ± 100	640 ± 75

STANDARD TORQUE FOR INCH FASTENERS

Exceptions to these torques are given in the Service Manual where needed.

INCH NUTS AND BOLTS		
THREAD SIZE inch	STANDARD TORQUE	
	(N•m)	(lb•ft)
1/4	12 ± 3	9 ± 2
5/16	25 ± 6	18.0 ± 4.5
3/8	47 ± 9	35 ± 7
7/16	70 ± 15	50 ± 11
1/2	105 ± 20	75 ± 15
9/16	160 ± 30	120 ± 20
5/8	215 ± 40	160 ± 30
3/4	370 ± 50	275 ± 35
7/8	620 ± 80	460 ± 60
1	900 ± 100	660 ± 75
1-1/8	1300 ± 150	950 ± 100
1-1/4	1800 ± 200	1325 ± 150
1-3/8	2400 ± 300	1800 ± 225
1-1/2	3100 ± 350	2300 ± 250

INCH TAPERLOCK STUDS		
THREAD SIZE inch	STANDARD TORQUE	
	(N•m)	(lb•ft)
1/4	8 ± 3	6 ± 2
5/16	17 ± 5	13 ± 4
3/8	35 ± 5	26 ± 4
7/16	45 ± 10	33 ± 7
1/2	65 ± 10	48 ± 7
5/8	110 ± 20	80 ± 15
3/4	170 ± 30	125 ± 22
7/8	260 ± 40	190 ± 30
1	400 ± 60	300 ± 45
1-1/8	500 ± 70	370 ± 50
1-1/4	650 ± 80	480 ± 60
1-3/8	750 ± 90	550 ± 65
1-1/2	870 ± 100	640 ± 75

O-RING FACE SEAL FITTINGS

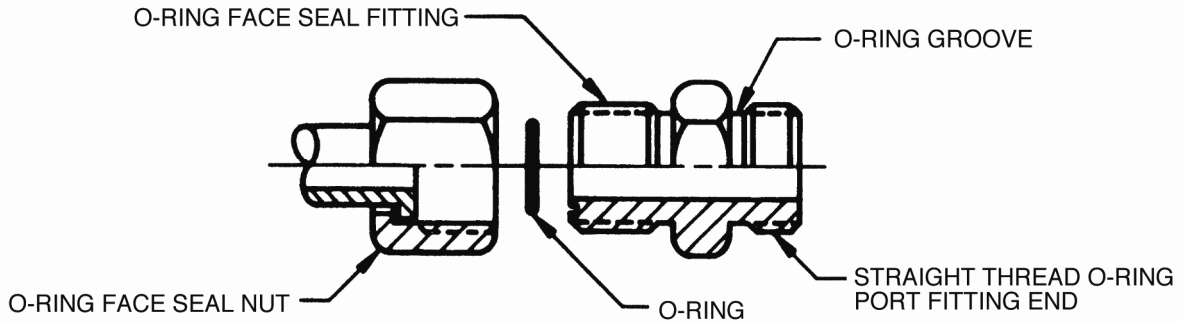

IDAS001B

STRAIGHT THREAD O-RING FITTING (FOR O-RING FACE SEAL FITTING ONLY)

THREAD SIZE inch	STANDARD TORQUE	
	(N•m)	(lb•ft)
5/16-24	5.0 ± 1.5	45±15 lbiin
3/8-24	12 ± 2	110±20 lbiin
7/16-20	20 ± 4	15 ± 3
1/2-20	30 ± 5	22 ± 4
9/16-18	40 ± 5	30 ± 4
3/4-16	100 ± 15	75 ± 10
7/8-14	135 ± 15	100 ± 10
1 1/16-12	200 ± 25	150 ± 20
1 3/16-12	250 ± 25	185 ± 20
1 5/16-12	300 ± 40	225 ± 30
1 5/8-12	300 ± 40	225 ± 30
1 7/8-12	300 ± 40	225 ± 30
2 1/2-12	300 ± 40	225 ± 30

O-RING FACE SEAL FITTING NUT

THREAD SIZE inch	STANDARD TORQUE	
	(N•m)	(lb•ft)
9/16-18	16 ± 3	12 ± 2
11/16-16	30 ± 4	22 ± 3
13/16-16	50 ± 7	37 ± 5
1-14	90 ± 10	65 ± 7
1 3/16-12	120 ± 15	90 ± 10
1 7/16-12	160 ± 20	120 ± 15
1 11/16-12	190 ± 20	140 ± 15
2-12	215 ± 25	160 ± 20

FITTING INSTALLATION

HYDRAULIC LINE INSTALLATION

1. For a metal tube to hose installation, install the tube and tighten all bolts finger tight.
2. Tighten the bolts at the rigid end.
3. Install the hose and tighten all bolts finger tight.
4. Put the hose in a position so that it does not make contact with the machine or another hose.
5. Tighten the bolts on both connections.
6. Start the engine.
7. Move the implement control levers to all positions.
8. Look at the hose during movement of the implement. Make sure hose is not in contact with the machine or other hoses.
9. Shut off the engine.
10. If necessary, put the hose in a new position where it will not make contact when the implement is moved.

ASSEMBLY OF FITTINGS WITH STRAIGHT THREADS AND O-RING SEALS

This type of fitting is used in many applications. The tube end of the fitting will be different in design so that it can be used in many different applications. However, the installation procedure of the fitting is the same. If the tube end of the fitting body is the same as in the illustration (either an elbow or a straight body) it will be necessary to assemble the sleeve on the tube before connecting the tube to the end.

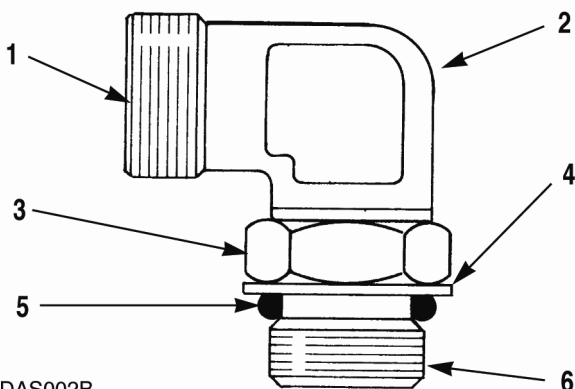

IDAS002B

ELBOW BODY ASSEMBLY

- (1) End of fitting body (connects to tube). (2) Fitting body.
 (3) Lock-nut. (4) Backup washer. (5) O-ring seal. (6) End of fitting that goes into other part.

1. Put locknut (3), backup washer (4) and O-ring seal (5) as far back on fitting body (2) as possible. Hold these components in this position. Turn the fitting into the part it is used on until backup washer (4) just makes contact with the face of the part it is used on.
2. To put the fitting assembly in its correct position, turn the fitting body (2) out (counterclockwise) a maximum of 359u. Tighten locknut (3) to the torque shown in the correct chart for the fitting used.

NOTE: If the fitting is a connector (straight fitting), the hex on the body takes the place of the locknut. To install this type fitting, tighten the hex against the face of the part it goes into.

TORQUES FOR FLARED AND O-RING FITTINGS

The torques shown in the charts that follow are to be used on the nut part of 37° Flared, 45° Flared and Inverted Flared fittings (when used with steel tubing), O-ring plugs, O-ring fittings and swivel nuts when used in applications to 3000 psi (20 700 kPa).

HOSE CLAMP-BAND TYPE

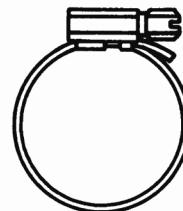

IDAS003B

CLAMP WIDTH	TORQUE ON NEW HOSE	RETIGHTENING TORQUE
7.9 mm (.312 in)	0.9 ± 0.2 N im 8 ± 2 lbiin	0.7 ± 0.2 N im 6 ± 2 lb iin
13.5 mm (.531 in)	4.5 ± 0.5 N im 40 ± 5 lbiin	3.0 ± 0.5 N im 25 ± 5 lb iin
15.9 mm (.625 in)	7.5 ± 0.5 N im 65 ± 5 lbiin	4.5 ± 0.5 N im 40 ± 5 lb iin

37° FLARED AND STRAIGHT THREAD O-RING FITTINGS

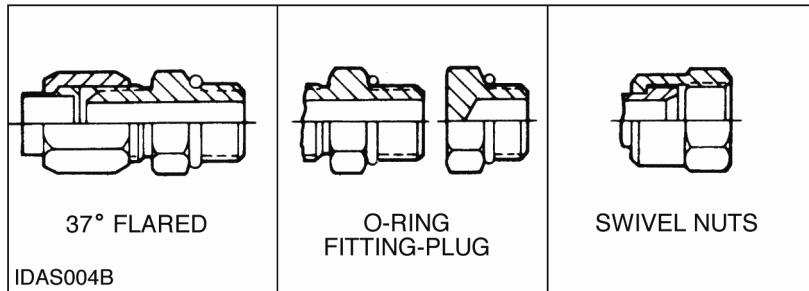

37° FLARED AND STRAIGHT THREAD O-RING FITTINGS (EXCEPT O-RING FACE SEAL FITTINGS)

NOMINAL TUBE O.D.		THREAD SIZE inch	STANDARD TORQUE	
METRIC	INCH		(N•m)	(lb•ft)
3.18	.125	5/16	5.0 ± 1.5	4 ± 1
4.76	.188	3/8	11.0 ± 1.5	8 ± 1
6.35	.250	7/16	16 ± 2	12 ± 1
7.94	.312	1/2	20 ± 5	15 ± 4
9.52	.375	9/16	25 ± 5	18 ± 4
9.52	.375	5/8	35 ± 5	26 ± 4
12.70	.500	3/4	50 ± 7	37 ± 5
15.88	.625	7/8	65 ± 7	48 ± 5
19.05	.750	1-1/16	100 ± 10	75 ± 7
22.22	.875	1-3/16	120 ± 10	90 ± 7
25.40	1.000	1-5/16	135 ± 15	100 ± 11
31.75	1.250	1-5/8	180 ± 15	135 ± 11
38.10	1.500	1-7/8	225 ± 15	165 ± 11
50.80	2.000	2-1/2	320 ± 30	240 ± 22

TIGHTENING OTHER FITTINGS

Hi Duty (Shear sleeve) Tube Fittings

After tube has been put through the nut and makes contact against the tube shoulder in the fitting body, turn the nut with a wrench until a small decrease in torque is felt. This is an indication that the sleeve has been broken off the nut. Hold the tube to prevent turning and tighten the nut 1-1/2 turns.

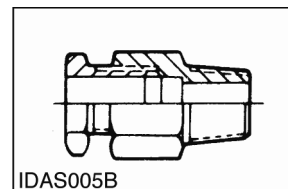

Hi Seal Fittings

Put nut and sleeve over the tubing with the short heavy end of the sleeve facing the end of tubing. Put the tube end against the counterbore in the body of the fitting and tighten until nut is over the last thread on the body. The remainder of space is used whenever the fitting is removed and installed again.

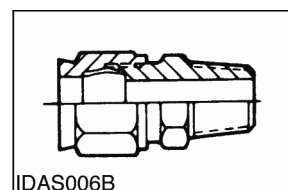

45° FLARED AND 45° INVERTED FLARE FITTINGS

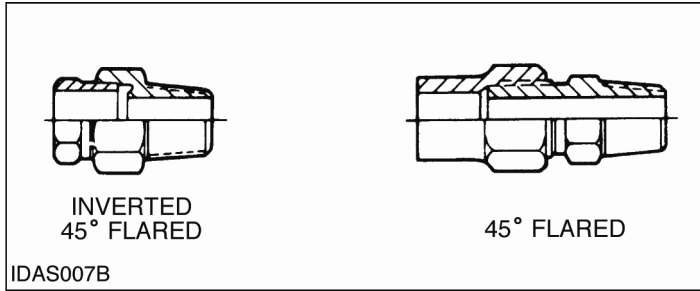

45° FLARED AND 45° INVERTED FLARE FITTINGS				
NOMINAL TUBE O.D.		THREAD SIZE inch	STANDARD TORQUE	
METRIC	INCH		(N•m)	(lb•ft)
3.18	.125	5/16	5.0 ± 1.5	4 ± 1
4.76	.188	3/8	8.0 ± 1.5	6 ± 1
6.35	.250	7/16	11 ± 2	8 ± 1
7.94	.312	1/2	17 ± 3	13 ± 2
9.52	.375	5/8	30 ± 3	22 ± 2
11.11	.438	11/16	30 ± 3	22 ± 2
12.70	.500	3/4	38 ± 4	28 ± 3
15.88	.625	7/8	50 ± 5	37 ± 4
19.05	.750	1-1/16	90 ± 8	65 ± 6
22.22	.875	1-1/4	100 ± 10	75 ± 7

TIGHTENING OTHER FITTINGS

Ermeto Tube Fittings

Put nut and sleeve over the tube with head or shoulder end of sleeve next to nut. Push tube into counterbore of fitting body as far as possible. Turn nut clockwise until sleeve holds tube and prevents movement. Tighten the nut 1-1/4 turns more to seat sleeve and give a locking action. When necessary to assemble again, put sleeve over tube and tighten nut until a sudden increase in torque is felt. Then tighten 1/6 to 1/3 turn more to seat the sleeve.

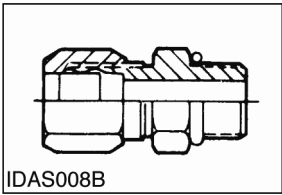

Flex Fittings

Put nut and sleeve over the tubing and push tube in to counterbore of fitting body as far as possible. Tighten the nut until it is against the hex part of the fitting body.

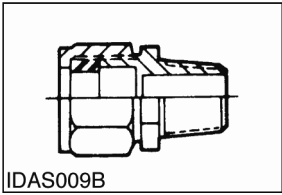

AIR CONDITIONING AND TAPERED PIPE THREAD FITTINGS

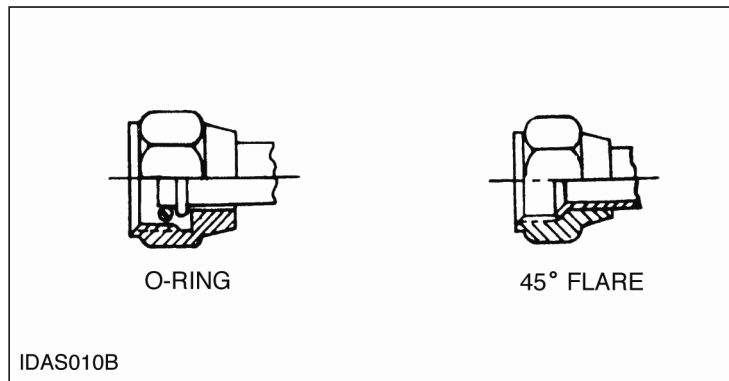

AIR CONDITIONING FITTINGS						
O-RING FITTING END			45° FLARE FITTING END			
THREAD SIZE inch	STANDARD TORQUE		STEEL TUBES		ALUMINUM TUBES	
			STANDARD TORQUE		STANDARD TORQUE	
	N•m	(lb•ft)	N•m	(lb•ft)	N•m	(lb•ft)
5/8-18	18 ± 4	13 ± 3	30 ± 3	22 ± 2	23 ± 3	17 ± 2
3/4-16	37 ± 4	27 ± 3	52 ± 5	38 ± 4	33 ± 4	24 ± 3
7/8-14	40 ± 4	30 ± 3	60 ± 7	44 ± 5	38 ± 4	28 ± 3
1 1/16-14	45 ± 5	33 ± 4	75 ± 8	55 ± 6	50 ± 5	37 ± 4

TAPERED PIPE THREAD FITTINGS				
PIPE THREAD SIZE inch	STANDARD TORQUE			
	THREADS WITH 1E2200E SEALANT		THREADS WITHOUT SEALANT	
	N•m	(lb•ft)	N•m	(lb•ft)
1/16-27	15	11	20	15
1/8-27	20	15	25	18
1/4-18	25	18	35	26
3/8-18	35	26	45	33
1/2-14	45	33	60	45
3/4-14	60	45	75	55
1-11 1/2	75	55	90	65
1 1/4-11 1/2	95	70	110	80
1 1/2-11 1/2	110	80	130	95
2-11 1/2	130	95	160	120

Micro Controller Control System

Specification

System Operation

Testing & Adjusting

B10R-5, B13R-5, B15R-5, B16R-5

Important Safety Information

Most accidents involving product operation, maintenance and repair are caused by failure to observe basic safety rules or precautions. An accident can often be avoided by recognizing potentially hazardous situations before an accident occurs. A person must be alert to potential hazards. This person should also have the necessary training, skills and tools to perform these functions properly.

Improper operation, lubrication, maintenance or repair of this product can be dangerous and could result in injury or death.

Do not operate or perform any lubrication, maintenance or repair on this product, until you have read and understood the operation, lubrication, maintenance and repair information.

Safety precautions and warnings are provided in this manual and on the product. If these hazard warnings are not heeded, bodily injury or death could occur to you or other persons.

The hazards are identified by the "Safety Alert Symbol" and followed by a "Signal Word" such as "WARNING" as shown below.



The meaning of this safety alert symbol is as follows:

Attention ! Become Alert ! Your Safety is Involved.

The message that appears under the warning, explaining the hazard, can be either written or pictorially presented.

Operations that may cause product damage are identified by NOTICE labels on the product and in this publication.

DOOSAN cannot anticipate every possible circumstance that might involve a potential hazard. The warnings in this publication and on the product are therefore not all inclusive. If a tool, procedure, work method or operating technique not specifically recommended by DOOSAN is used, you must satisfy yourself that it is safe for you and others. You should also ensure that the product will not be damaged or made unsafe by the operation, lubrication, maintenance or repair procedures you choose.

The information, specifications, and illustrations in this publication are on the basis of information available at the time it was written. The specifications, torques, pressures, measurements, adjustments, illustrations, and other items can change at any time. These changes can affect the service given to the product. Obtain the complete and most current information before starting any job. DOOSAN dealers have the most current information available.

Index

Specifications

Component Measurements	5
Controller AS Specification.....	6
Instrument Panel Layout	8
Fuses	9
Assembly Layout of Controller.....	9
Assembly Layout of Motors	9
Control Panel Layout	10

Systems Operation

Glossary	11
General Information	13
Installation and Wiring.....	17

Testing and Adjusting

Preparation Tests and Check.....	23
Programmable Parameters	25
Some Functions Management.....	30

Diagnostic and Troubleshooting

General Description	31
Alarm List	31
Troubleshooting Problem List.....	40
System Tests and Adjustments	82
Electrical System Adjustment.....	83

Instrument Panel

Instrument Panel.....	86
Display Keys Utilization.....	90
Parameter Calibration	91
Sensor Initial Setting.....	94
Default Setting	94
Diagnostic Mode	95
List of diagnostic (Table 9)	96
Accessing Stored Error Codes	97

Eye Software Interface

General Information.....	100
Installation.....	100
Features.....	101
Main Menu	102
Troubleshooting of Eye Program	129

Appendix

Appendix A : Parameter List.....	130
Appendix B : Error Code List	133
Appendix C : Contraction for dot matrix display.	139
F1. Alarm Code	139
F2. Calibration Code.....	140
F3. Diagnostic Code	142

Please Click Here To Download The Complete Manual
Download Other Manuals
If Having Any Questions Feel Free To Contact us

admin@servicemanualbit.com