

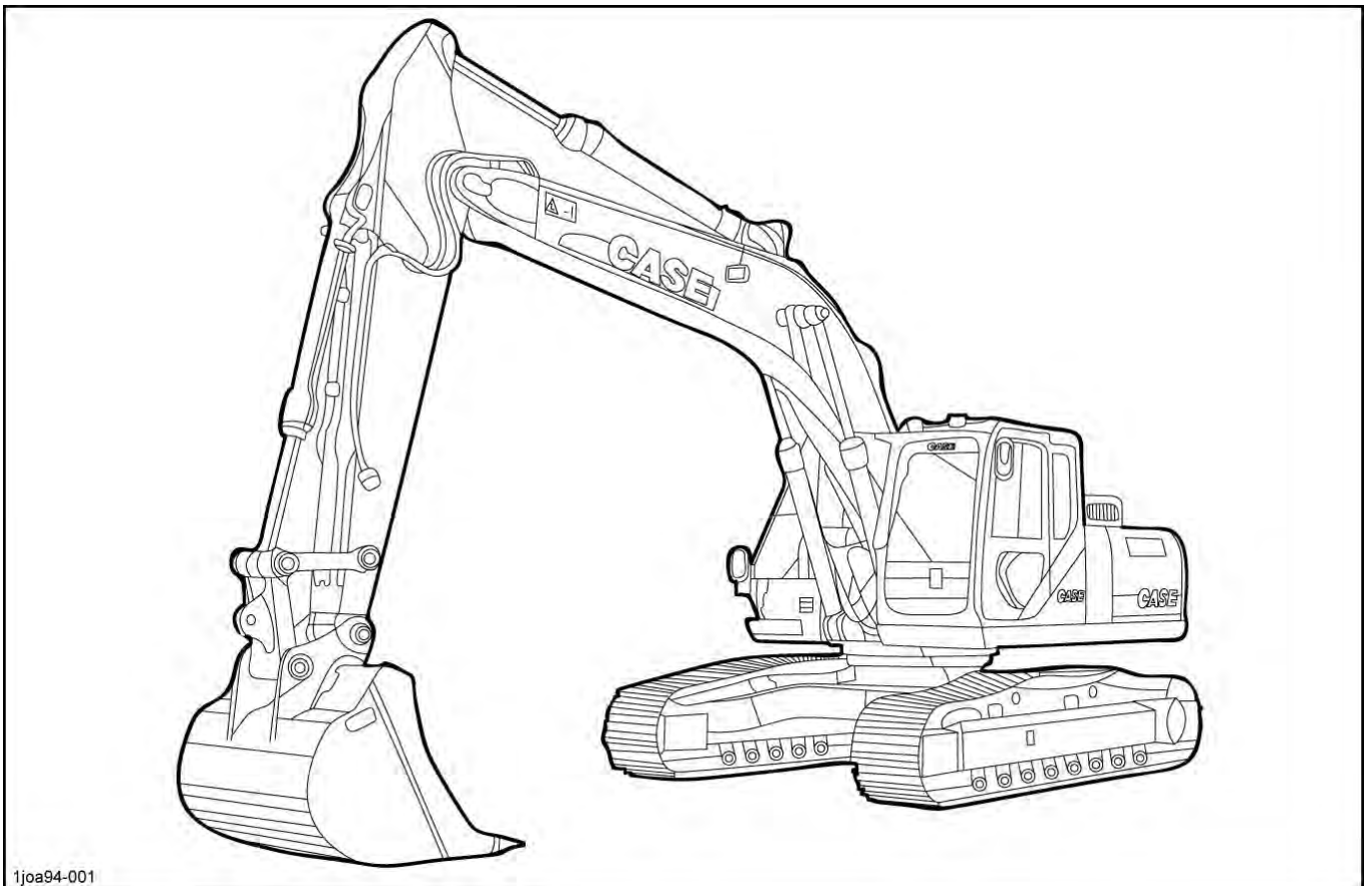

SERVICE MANUAL

Lep 84577148 EN



CX235C SR Tier 4
Crawler Excavator

CRAWLER EXCAVATOR CX235C SR TIER 4 SERVICE MANUAL

TABLE OF CONTENTS

DIVISION/SECTION	SECTION N°
1 GENERAL INFORMATION	
Safety, general information and standard torque data	1001
Specifications	1002A
Main Equipment Table	1002B
Main Unit Weight	1002C
Maintenance Standards	1002D
Bolt Size and Torque Table	1002E
Overall View	1002F
New Machine Performance Judgment Table	1002G
List of special tools	1003
Fluid and Lubricants	1004
Conversion Table	1005
Abbreviations	1900
2 ENGINE	
Removal and Installation of Engine Assembly	2000
Removal and installation of the fuel cooler engine inter-cooler radiator and oil cooler	2001
Removal and Installation of Turbo Charger	2004
Removal and Installation of EGR Valve	2005
Removal and Installation of Engine Hood	2006
Removal and Installation of Muffler	2007
Primary specifications	2401
Removal and Installation of Cylinder Head	2415
Removal and Installation of Cylinder Block	2425
Lubrication System	2445
Cooling System	2455
Removal and Installation of Exhaust Manifold	2465
Disassembly, Removal and Installation of DPD Assembly	2470
3 FUEL SYSTEM	
Removal and Installation of Fuel Tank	3001
Removal and Installation of Fuel Supply Pump	3004A
Removal and Installation of Common Rail Assembly	3004B
Removal and Installation of Injector	3005
4 ELECTRICAL SYSTEM	
Electrical and Engine Basic Functions	4001A
Service Support	4001B
Function, Structure, Operation	4001C
Symptom	4001E
Functional Inspection	4001F
Engine, Electronic and Programming Maintenance Precautions	4001G
Removal and Installation of Starter Motor	4004
Removal and Installation of Alternator	4005
Preheating System	4008
Electrical Equipment Layout Diagram	4020A
Connection Connector Pin Layout	4020B
Sequence Circuit Diagram	4020C
Engine-side DTC List	4021
Main Unit-side DTC List	4022
Introduction to the trouble diagnosis	4023B
Engine Control System	4023D
Engine-side Trouble	4023G

TABLE OF CONTENTS

DIVISION/SECTION	SECTION N°
Main Unit-side Trouble	4023H
Data Reference Values	4023K
Electrical Wiring Diagram	4040
5 UNDERCARRIAGE	
Removal and Installation of Shoe Assembly	5001A
Removal and Installation of Shoe Plate	5001B
Removal and Installation of Upper Roller	5003A
Assembly and Disassembly of Upper Roller	5003B
Removal and Installation of Lower Roller	5003C
Assembly and Disassembly of Lower Roller	5003D
Removal and Installation of the Sprocket	5004
Removal and Installation of Take-up Roller	5005A
Assembly and Disassembly of Take-up Roller	5005B
Removal and Installation of Grease Cylinder	5005C
Assembly and Disassembly of Tension Shock Absorber	5005D
6 DRIVE TRAIN	
Removal and Installation of Travel Motor	6001
Assembly and Disassembly of Travel Motor	6002
Removal and Installation of Swing Unit	6003
Assembly and Disassembly of Swing Unit	6004
7 UNDERCARRIAGE HYDRAULICS	
8 UPPERSTRUCTURE HYDRAULICS	
Overall view	8001A
Port Diagram	8001B
Pump P-Q Diagram	8001C
Pressure Measurement and Adjustment Procedures	8001D
Hydraulic Pump Flow Measurement Procedures	8001E
Drain Volume Measurement Procedures	8001F
Air Bleed Procedure	8001G
Removal and Installation of Hydraulic Oil Tank	8002
Removal and Installation of Hydraulic Pump	8003
Removal and Installation of Control Valve	8004
Removal and Installation of Bucket Cylinder	8005A
Removal and Installation of Arm Cylinder	8005B
Removal and Installation of Boom Cylinder	8005C
Removal and Installation of Center Joint	8006
Removal and Installation of Travel Remote Control Valve	8007A
Removal and Installation of Operation Remote Control Valve	8007B
Removal and Installation of 5 Stack Solenoid	8007C
Removal and Installation of Cushion Valve	8007D
Procedures for Assembly and Disassembly of Hydraulic Pump Main Unit	8008
Pump Main Unit Maintenance Standards	8010
Procedures for Assembly and Disassembly of Control Valve	8011
Procedures for Operation/Assembly and Disassembly of Hydraulic Cylinder (made by KYB)	8012
Procedures for Assembly and Disassembly of Operation Remote Control Valve	8013
Procedures for Assembly and Disassembly of Travel Remote Control Valve	8014
Assembly and Disassembly of Cushion Valve	8016
Removal and Installation of Arm HBCV	8017A
Removal and Installation of Boom HBCV	8017B
Assembly and Disassembly of Center Joint	8018
Assembly and Disassembly of Swing Motor	8019
Explanation of Hydraulic Circuit and Operations (standard model)	8020A
Explanation of Hydraulic Circuit and Operations (option)	8020B

TABLE OF CONTENTS

DIVISION/SECTION	SECTION N°
Structure and Operation Explanation of Hydraulic Pump	8030A
Structure and Operation Explanation of Travel Motor	8030B
Structure and Operation Explanation of Swing Motor	8030C
Structure and Operation Explanation of Control Valve	8030D
5 Stack Solenoid Valve Operation Explanation	8030E
Structure and Operation Explanation of Upper Pilot Valve (remote control valve)	8030F
Structure and Operation Explanation of Travel Pilot Valve (remote control valve)	8030G
Structure and Operation Explanation of Cushion Valve	8030H
9 UPPERSTRUCTURE	
Removal and Installation of Counterweight	9002
Removal and Installation of Bucket	9003A
Removal and Installation of Bucket Link	9003B
Removal and Installation of Arm	9003C
Removal and Installation of Boom	9003D
Removal and Installation of Operator's Seat	9004
Removal and Installation of Cab Assembly	9005A
Removal and Installation of Wiper	9005B
Removal and Installation of Wiper Controller	9005C
Removal and Installation of Wiper Motor	9005D
Removal and Installation of Monitor	9005E
Removal and Installation of Cab Front Glass	9005F
Window Lock Adjustment Procedures	9005G
Cab Tightening torque	9005H
Air Conditioner Overall Diagram	9006
Assembly and Disassembly of Air Conditioner Units	9007
Removal and Installation of Compressor	9009
Removal and Installation of Condenser	9010
Removal and Installation of Receiver Dryer	9011
Air Conditioning Gas Vacuum and Filling Operations	9015
10 LARGE SIZE SCHEMATICS	
Large size hydraulic schematics	84591421EN
Large size electrical schematics	84591419EN

NOTE: CNH France Company reserves the right to make changes in the specification and design of the machine without prior notice and without incurring any obligation to modify units previously sold.

The description of the models shown in this manual has been made in accordance with the technical specifications known as of the date of design of this document.

All data given in this manual is subject to production variations. Dimensions and weights are provided with approximate values and the machine fitting shown in the illustrations may not correspond with standard models. For precise information on specific machine models and versions, please contact your CASE dealer.

Reproduction or translation, even partial, is prohibited without written authorization from CNH France Company.



Section

1001

Safety, general information and standard torque data

CONTENTS

GENERAL INFORMATION.....	3
Safety.....	4
ROPS Judgment Method.....	6
Bolt and Nut Tightening.....	9

Safety, general information and standard torque data

GENERAL INFORMATION

CLEANING

Clean all metal parts except bearings, in a suitable cleaning solvent or by steam cleaning.

Do not use caustic soda for steam cleaning.

After cleaning, dry and put oil on all parts.

Clean oil passages with compressed air.

Clean bearings in a suitable cleaning solvent, dry the bearings completely and put oil on the bearings.

INSPECTION

Check all parts when the parts are disassembled.

Replace all parts that have wear or damage.

Small scoring or grooves can be removed with a hone or crocus cloth.

Complete a visual inspection for indications of wear, pitting and the replacement of parts necessary to prevent early failures.

BEARINGS

Check bearings for easy action.

If bearings have a loose fit or rough action replace the bearing.

Wash bearings with a suitable cleaning solvent and permit to air dry.

DO NOT DRY BEARINGS WITH COMPRESSED AIR.

NEEDLE BEARINGS

Before you press needle bearings in a bore always remove any metal protrusions in the bore or edge of the bore.

Before you press bearings into position put petroleum jelly on the inside and outside diameter of the bearings.

GEARS

Check all gears for wear and damage.

Replace gears that have wear or damage.

Oil seals, O-rings and gaskets.

Always install new oil seals, O-rings and gaskets.

Put petroleum jelly on seals and O-rings.

SHAFTS

Check all shafts that have wear or damage.

Check the bearing and oil seal surfaces of the shafts for damage.

SERVICE PARTS

Always install genuine Case service parts.

When ordering refer to the

Parts Catalogue for the correct part number of the genuine Case replacement items.

Failures due to the use of other than genuine Case replacement parts are not covered by warranty.

LUBRICATION

Only use the oils and lubricants specified in the Operator's or Service Manuals.

Failures due to the use of non-specified oils and lubricants are not covered by warranty.

Safety, general information and standard torque data

Safety

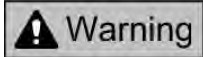

This symbol means ATTENTION! BECOME ALERT! YOUR SAFETY IS INVOLVED. The message that follows the symbol contains important information about safety. Carefully read the message. Make sure you fully understand the causes of possible injury or death.

To prevent injury always follow the Warning, Caution and Danger notes in this section and throughout the manual. Put the warning tag shown below on the key for the key switch when servicing or repairing the machine. One warning tag is supplied with each machine. Additional tags are available from your service parts supplier.

⚠ WARNING

Read the operator's manual to familiarize yourself with the correct control functions.

⚠ WARNING

Operate the machine and equipment controls from the seat position only. Any other method could result in serious injury.

⚠ WARNING

This is a one man machine, no riders allowed.

⚠ WARNING

**Before starting engine, study Operator's Manual safety messages.
Read all safety signs on machine.
Clear the area of other persons.
Learn and practice safe use of controls before operating.
It is your responsibility to understand and follow manufacturers instructions on machine operation, service and to observe pertinent laws and regulations.
Operator's and Service Manuals may be obtained from your CASE dealer.**

⚠ WARNING

**If you wear clothing that is too loose or do not use the correct safety equipment for your job, you can be injured.
Always wear clothing that will not catch on objects.
Extra safety equipment that can be required includes hard hat, safety shoes, ear protection, eye or face protection, heavy gloves and reflector clothing.**

⚠ WARNING

When working in the area of the fan belt with the engine running, avoid loose clothing if possible, and use extreme caution.

⚠ WARNING

When doing checks and tests on the equipment hydraulics, follow the procedures as they are written. DO NOT change the procedure.

⚠ WARNING

When putting the hydraulic cylinders on this machine through the necessary cycles to check operation or to remove air from a circuit, make sure all people are out of the way.

⚠ WARNING

Use insulated gloves or mittens when working with hot parts.

Safety, general information and standard torque data

⚠ WARNING

Lower all attachments to the ground or use stands to safely support the attachments before you do any maintenance or service.

⚠ WARNING

Pin sized and smaller streams of hydraulic oil under pressure can penetrate the skin and result in serious infection.

If hydraulic oil under pressure does penetrate the skin, seek medical treatment immediately.

Maintain all hoses and tubes in good condition.

Make sure all connections are tight.

Make a replacement of any tube or hose that is damaged or thought to be damaged.

DO NOT use your hand to check for leaks, use a piece of cardboard or wood.

⚠ WARNING

When removing hardened pins such as a pivot pin, or a hardened shaft, use a soft head (brass or bronze) hammer or use a driver made from brass or bronze and a steel head hammer.

⚠ WARNING

When using a hammer to remove and install pivot pins or separate parts using compressed air or using a grinder, wear eye protection that completely encloses the eyes (approved goggles or other approved eye protectors).

⚠ WARNING

Use suitable floor (service) jacks or chain hoist to raise wheels or tracks off the floor.
Always block machine in place with suitable safety stands.

⚠ WARNING

When servicing or repairing the machine, keep the shop floor and operator's compartment and steps free of oil, water, grease, tools, etc.

Use an oil absorbing material and/or shop cloths as required.

Use safe practices at all times.

⚠ WARNING

Some components of this machine are very heavy.
Use suitable lifting equipment or additional help as instructed in this Service Manual.

⚠ WARNING

Engine exhaust fumes can cause death.

If it is necessary to start the engine in a closed place, remove the exhaust fumes from the area with an exhaust pipe extension.

Open the doors and get outside air into the area.

⚠ WARNING

When the battery electrolyte is frozen, the battery can explode if (1), you try to charge the battery, or (2), you try to jump start and run the engine.

To prevent the battery electrolyte from freezing, try to keep the battery at full charge.

If you do not follow these instructions, you or others in the area can be injured.

Safety, general information and standard torque data

ROPS Judgment Method

1. Purpose

Check against the ROPS judgment criteria to judge whether the machine satisfies the ROPS criteria or not. The weight and boom of the machine greatly effects whether the ROPS judgment criteria is satisfied or not. The ROPS test assumes that the weight being used is the weight of the machine when the maximum number of selectable options are mounted (as of 2009).

However, depending on the derivative machinery or the order details, the weight and boom position may differ from the assumed weight or position.

2. Criteria for judging whether a machine satisfies the ROPS criteria

1) Weight

The weight must not be over the weight shown below for each class.

If the weight is exceeded, there is a danger that the cab could be damaged and the operator could die or sustain a serious injury when the machine falls over.

If the weight exceeds the stipulated weight, the machine will not satisfy the ROPS criteria.

• Weight (X3 model)

To satisfy the ROPS criteria, the weight must not be over the indicated weight. (The below weights are the weights indicated on the nameplate within the ROPS cab)

Machine body total weight	Class
16000 kg (35274.146 lb) or less	CX75C CX145C
20500 kg (45195.000 lb) or less	CX130C CX160C CX180C
28000 kg (61729.756 lb) or less	CX235C
31000 kg (68343.658 lb) or less	CX210C CX250C CX250C LR CX300C
40000 kg (88185.365 lb) or less	CX370C
50000 kg (110231.707 lb) or less	CX470C

* The ROPS test assumes that the CX470C has a cage guard (alone).

Machine body total weight	Class
16000 kg (35274.146 lb) or less	CX75C CX145C
20500 kg (45195.000 lb) or less	CX130C CX160C CX180C
28000 kg (61729.756 lb) or less	CX235C
31000 kg (68343.658 lb) or less	CX210C CX250C CX250C LR CX300C
50000 kg (110231.707 lb) or less	CX470C

* The ROPS test assumes that the CX470C has a cage guard (alone).

• Weight (X2 model)

To satisfy the ROPS criteria, the weight must not be over the indicated weight. (The below weights are the weights indicated on the nameplate within the ROPS cab)

Machine body total weight	Class
26600 kg (58643.268 lb) or less	CX130B CX160B CX180B CX210B CX240B

Safety, general information and standard torque data

2) Boom position

⚠ WARNING

- If the machine has been modified so that the boom position has been lowered, the machine will not satisfy the ROPS criteria.
- It is necessary to consult with our company if it is possible that the boom's position has been lowered by modification.
- The extent to which a boom position has moved cannot be determined in the same way for all machines.

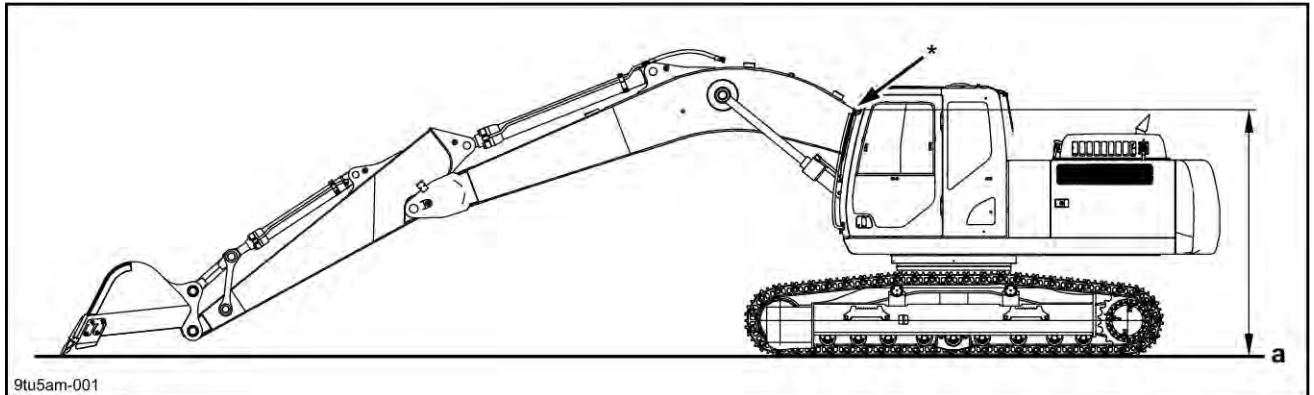

a Ground point

With the tip of the bucket in contact with the ground surface at maximum work radius, if the position (* in the diagram) that overlaps with the cab when viewed from the side is markedly lower than that of a standard machine (standard arm), the machine will not satisfy the ROPS criteria.

Also, with a machine body with a cab mounted that can withstand up to 31 tons, the effect of mounting a 24 ton machine, which is near the restriction weight, and a 21 ton machine to the same cab will not be the same.

3. Prohibited items

- Modifications that reduce the strength of a platform that has a cab with a ROPS mounted to it. (Actions or modifications that reduce the functionality of the anchoring part at the left-rear of the cab)
- Modifications that effect the strength of the ROPS of a cab.

A forbidden all modifications (red part)	All modifications (grinding, welding, drilling holes, removing, etc.) are prohibited.
Allow under specified conditions (gray part)	Removal of parts is prohibited. Bar welding and making holes [up to diameter 20 mm (0.787 in)] by drilling are possible.

Safety, general information and standard torque data

[X3 Cab]

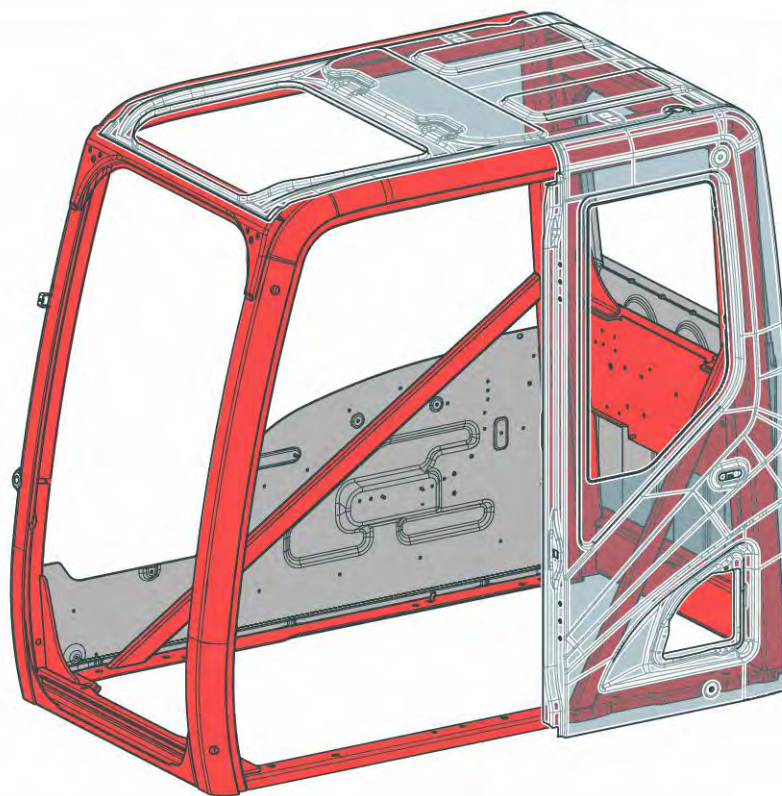

9tu5am-002

[X2 Cab]

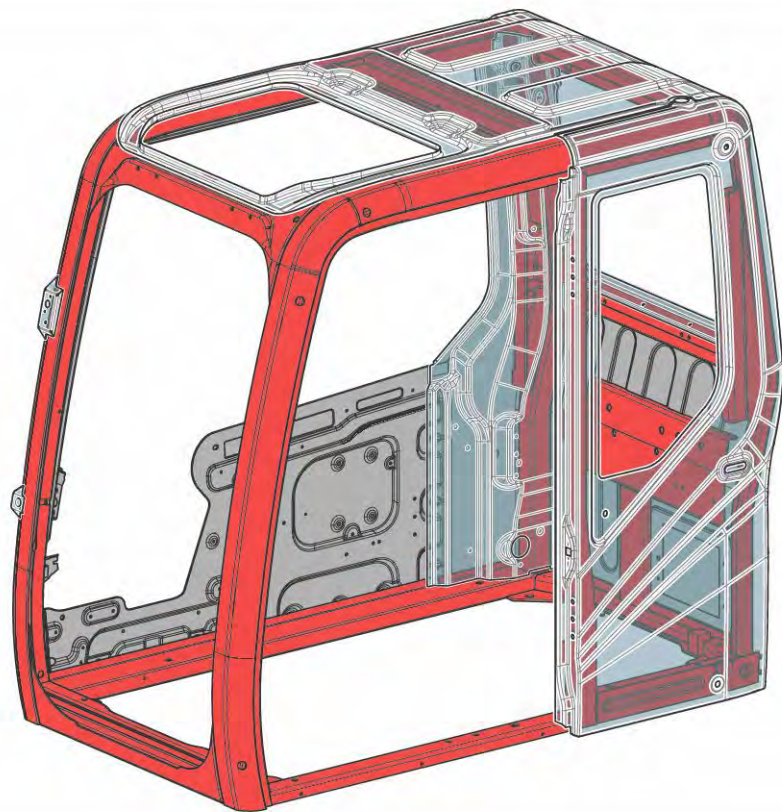

9tu5am-004

- In general, high cabs do not satisfy the ROPS criteria. (It is necessary to consult with our company to check if the high cab model satisfies the ROPS criteria.)

Safety, general information and standard torque data

Bolt and Nut Tightening

- Tighten alternating between left and right and top and bottom so that uniform tightening force is applied.

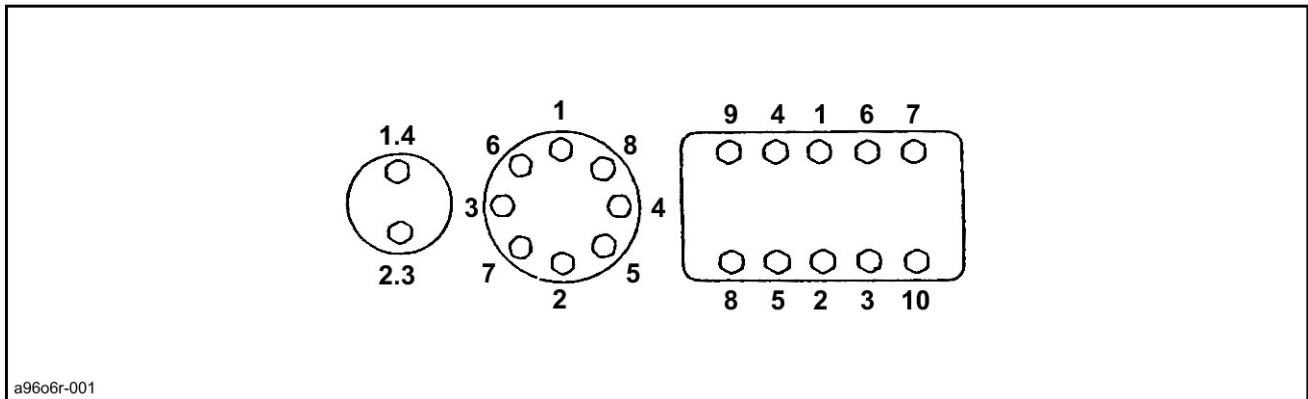

a96o6r-001

- If Loctite was used on a removed bolt (there is something white sticking to the bolt when it is removed), clean the old Loctite off with cleaning fluid, dry the bolt, then apply 2 - 3 drops of Loctite to the thread section of the bolt.

Torque table

Bolt nominal diameter (size)		M6	M8	M10	M12	M14	M16	M18	M20	
Hexagon bolt	Wrench	mm (in)	10 (0.394)	13 (0.512)	17 (0.669)	19 (0.748)	22 (0.866)	24 (0.945)	27 (1.063)	30 (1.181)
	Tightening torque	N·m (lbf·ft)	6.9 (5.090)	19.6 (14.459)	39.2 (28.917)	58.8 (43.376)	98.1 (72.367)	156.9 (115.743)	196.1 (144.661)	294.2 (217.028)
Hexagon socket head bolt	Wrench	mm (in)	5 (0.197)	6 (0.236)	8 (0.315)	10 (0.394)	12 (0.472)	14 (0.551)	14 (0.551)	17 (0.669)
	Tightening torque	N·m (lbf·ft)	8.8 (6.492)	21.6 (15.934)	42.1 (217.028)	78.5 (57.909)	117.7 (86.826)	176.5 (130.202)	245.2 (180.881)	343.2 (253.175)



Section

1002A

Specifications

CONTENTS

CX235C SR.....	3
Main Data	3
Performance	3
Main Unit Dimensions	3
Engine	3
Cooling System	3
Upper Side Work System	4
Operating Device	4
Swing Units	5
Travel Lower Body	5
Hydraulic Equipment	5
Hydraulic Device	5
Control Valve and Cylinder	6
Capacities, Filters.....	6
Coolant and Oil Capacities	6
Hydraulic Oil Filters	6
Fuel Filter.....	6
CX235C SR (Blade).....	6
Main Data	6
Performance	6
Main Unit Dimensions	7
Engine	7
Cooling System	7
Upper Side Work System	7
Operating Device	8
Swing Units	8
Travel Lower Body	9
Hydraulic Equipment	9
Hydraulic Device	9
Control Valve and Cylinder	9
Capacities, Filters.....	9
Coolant and Oil Capacities	9
Hydraulic Oil Filters	10
Fuel Filter.....	10

Thanks for your reading.

Please click here to download complete manual instantly.

And can also choose other manuals.

Feel free --->write to me with any questions.

Our service email:

manuals007@hotmail.com