

**CX220C Series 2
CX240C
Hydraulic Excavator**

Service Manual

Part Number
48024959
1st Edition
English 11/2016

CASE
CONSTRUCTION



SERVICE MANUAL

**CX220C SERIES 2 Standard model, TIER 3 level engine
CX240C Crawler excavator-Mass excavator - TIER 3**

Contents

INTRODUCTION

Engine.....	10
[10.001] Engine and crankcase	10.1
[10.216] Fuel tanks	10.2
[10.254] Intake and exhaust manifolds and muffler	10.3
[10.310] Aftercooler.....	10.4
[10.400] Engine cooling system	10.5
Hydraulic systems.....	35
[35.106] Variable displacement pump	35.1
[35.102] Pump control valves.....	35.2
[35.353] Hydraulic travel system	35.3
[35.359] Main control valve.....	35.4
Hydraulic systems.....	35
[35.000] Hydraulic systems.....	35.5
[35.300] Reservoir, cooler, and filters.....	35.6
[35.304] Combination pump units	35.7
[35.357] Pilot system	35.8
[35.355] Hydraulic hand control	35.9
[35.356] Hydraulic foot control.....	35.10
[35.352] Hydraulic swing system	35.11
[35.354] Hydraulic central joint	35.12
[35.736] Boom hydraulic system	35.13
[35.737] Dipper hydraulic system.....	35.14
[35.738] Excavator and backhoe bucket hydraulic system.....	35.15
[35.360] Hammer and rotating bucket hydraulic system	35.16
Frames and ballasting	39

[39.140] Ballasts and supports	39.1
Tracks and track suspension	48
[48.130] Track frame and driving wheels	48.1
[48.100] Tracks	48.2
[48.134] Track tension units	48.3
[48.138] Track rollers	48.4
Cab climate control	50
[50.100] Heating	50.1
[50.200] Air conditioning	50.2
Electrical systems	55
[55.000] Electrical system	55.1
[55.010] Fuel injection system	55.2
[55.013] Engine oil system	55.3
[55.015] Engine control system	55.4
[55.201] Engine starting system	55.5
[55.640] Electronic modules	55.6
[55.036] Hydraulic system control	55.7
[55.051] Cab Heating, Ventilation, and Air-Conditioning (HVAC) controls	55.8
[55.050] Heating, Ventilation, and Air-Conditioning (HVAC) control system	55.9
[55.100] Harnesses and connectors	55.10
[55.301] Alternator	55.11
[55.302] Battery	55.12
[55.404] External lighting	55.13
[55.416] Swing control system	55.14
[55.417] Travel control system	55.15
[55.530] Camera	55.16
[55.518] Wiper and washer system	55.17
[55.514] Cab lighting	55.18

[55.408] Warning indicators, alarms, and instruments	55.19
[55.512] Cab controls.....	55.20
[55.950] Hammer electric system	55.21
[55.992] Anti-theft system	55.22
[55.DTC] FAULT CODES.....	55.23
Booms, dippers, and buckets	84
[84.910] Boom.....	84.1
[84.912] Dipper arm	84.2
[84.100] Bucket.....	84.3
Platform, cab, bodywork, and decals	90
[90.100] Engine hood and panels	90.1
[90.120] Mechanically-adjusted operator seat.....	90.2
[90.150] Cab.....	90.3
[90.156] Cab windshield and windows	90.4



INTRODUCTION

Contents

INTRODUCTION

Foreword - Important notice regarding equipment servicing (*)	3
Safety rules (*)	4
Safety rules - General information (*)	5
Safety rules - Personal safety (*)	6
Safety rules - Cab protective structure (*)	8
Torque - Bolt and nut (*)	9
Torque - Special torque settings (*)	10
Basic instructions - Shop and assembly (*)	14
General specification (*)	16
General specification - Main equipment (*)	20
Weight (*)	27
Dimension (*)	29
Dimension (*)	31
Conversion factors (*)	34
Consumables (*)	46
Capacities (*)	49
Abbreviation (*)	50
Product identification (*)	53
Product identification - Machine orientation (*)	55

(*) See content for specific models

Foreword - Important notice regarding equipment servicing

CX220C SERIES 2 Standard model, TIER 3 level engine	LA
CX240C Crawler excavator-Mass excavator - TIER 3	LA

All repair and maintenance work listed in this manual must be carried out only by qualified dealership personnel, strictly complying with the instructions given, and using, whenever possible, the special tools.

Anyone who performs repair and maintenance operations without complying with the procedures provided herein shall be responsible for any subsequent damages.

The manufacturer and all the organizations of its distribution chain, including - without limitation - national, regional, or local dealers, reject any responsibility for damages caused by parts and/or components not approved by the manufacturer, including those used for the servicing or repair of the product manufactured or marketed by the manufacturer. In any case, no warranty is given or attributed on the product manufactured or marketed by the manufacturer in case of damages caused by parts and/or components not approved by the manufacturer.

The manufacturer reserves the right to make improvements in design and changes in specifications at any time without notice and without incurring any obligation to install them on units previously sold. Specifications, descriptions, and illustrative material herein are as accurate as known at time of publication but are subject to change without notice.

In case of questions, refer to your CASE CONSTRUCTION Sales and Service Networks.

Safety rules

CX220C SERIES 2 Standard model, TIER 3 level engine	LA
CX240C Crawler excavator-Mass excavator - TIER 3	LA

Personal safety





This is the safety alert symbol. It is used to alert you to potential personal injury hazards. Obey all safety messages that follow this symbol to avoid possible death or injury.

Throughout this manual you will find the signal words DANGER, WARNING, and CAUTION followed by special instructions. These precautions are intended for the personal safety of you and those working with you.

Read and understand all the safety messages in this manual before you operate or service the machine.

 DANGER indicates a hazardous situation that, if not avoided, will result in death or serious injury.

 WARNING indicates a hazardous situation that, if not avoided, could result in death or serious injury.

 CAUTION indicates a hazardous situation that, if not avoided, could result in minor or moderate injury.

FAILURE TO FOLLOW DANGER, WARNING, AND CAUTION MESSAGES COULD RESULT IN DEATH OR SERIOUS INJURY.

Machine safety

NOTICE: Notice indicates a situation that, if not avoided, could result in machine or property damage.

Throughout this manual you will find the signal word Notice followed by special instructions to prevent machine or property damage. The word Notice is used to address practices not related to personal safety.

Information

NOTE: Note indicates additional information that clarifies steps, procedures, or other information in this manual.

Throughout this manual you will find the word Note followed by additional information about a step, procedure, or other information in the manual. The word Note is not intended to address personal safety or property damage.

Safety rules - General information

CX220C SERIES 2 Standard model, TIER 3 level engine	
CX240C Crawler excavator-Mass excavator - TIER 3	LA

Cleaning

Clean the metal parts with cleaning solution that meets the standard and steam cleaning. (except for bearings)

After cleaning, dry well, and inject oil in all parts.

Also inject oil into the bearings after drying.

Inspection

When disassembling parts, check all the parts.

If there are any worn or damaged parts, replace them.

Inspect carefully to prevent initial breakdowns.

Bearing

Replace any loose bearings.

Air dry bearings before installing them.

Needle bearing

When inserting needle bearings, be very careful not to damage them.

Apply grease to the section where the needle bearing will be inserted.

Gear

Check that there is no wear and no damage.

Oil seal, O-ring, gasket

Always install new oil seals, O-rings, and gaskets.

Apply grease to sections where oil seals and O-rings will be inserted.

Shaft

Check that there is no wear and no damage.

Check the bearings and check for damaged oil seals on the shaft.

Service parts

Install CASE CONSTRUCTION genuine service parts.

When placing an order, check the parts catalog. It contains the CASE CONSTRUCTION genuine part numbers.

Any breakdowns arising from the installation of non-genuine parts are not covered by the warranty.

Lubricants (fuel, hydraulic oil)

Use the oil from the specified company or specified in the operator's manual or service Manual.

Any breakdowns arising from any fuel or hydraulic oil other than those specified are not covered by the warranty.

Safety rules - Personal safety

CX220C SERIES 2 Standard model, TIER 3 level engine	
CX240C Crawler excavator-Mass excavator - TIER 3	LA

WARNING:

This symbol indicates a precaution.
It gives information concerning the safety of the operator and those in the surroundings.
Read and understand these precautions thoroughly before performing the work.

Always comply with warnings and precautions so as to avoid any accidents.

This section covers information related to overall safety.

Check whether all warning labels are in place.

Additional labels can be ordered from Service Parts.

WARNING:

Read the operator's manual to gain a thorough understanding of machine control operations.

WARNING:

Perform any machine operations from the seating position.
Any other method may cause severe injuries.

WARNING:

Only the one operator is to ride on the machine. No one else is to ride on it.

WARNING:

Check the safety messages in the operator's manual before starting the engine.
Check all the warning labels on the machine.
Check that no one is within the machine's operating range.
Check the operating methods in a safe location before starting the actual work.
Understand the machine operations well, then operate in compliance with all service-related laws and regulations.
The operator's manual can be purchased at your CASE CONSTRUCTION dealer.

WARNING:

Working with sloppy clothes or clothes with which safety cannot be ensured leads to damage to the machine and injury to the operator.
Always wear clothes that ensures safety.
In order to work more safely, it is recommended to wear additional safety equipment.
Helmet, safety shoes, ear protection, goggles, work clothes, and gloves

WARNING:

Pay careful attention when working with the engine running.

WARNING:

Check hydraulic equipment.
Work according to the procedure.
Do not change the procedure.

INTRODUCTION

 WARNING:

Check that there is no one in the surroundings before draining the pressure from hydraulic circuits during machine hydraulic cylinder inspection.

 WARNING:

Use gloves when handling high-temperature parts.

 WARNING:

Bring the lower parts or attachments in contact with the ground before inspecting or repairing them.

 WARNING:

Check that hoses and tubes are securely connected.
If there is any damage to a hose or tube, replace it.
Do not check for oil leaks by hand. Use cardboard or wood.

 WARNING:

When removing an attachment pin or other hardened pin, use a hammer that has a soft head.

 WARNING:

Wear eye protection when using a hammer to install a pin or when working with a grinder.
At this time, use goggles or eye protectors that meet standards.

 WARNING:

Park the machine in a safe location when repairing or inspecting it.

 WARNING:

Use work site protection when repairing the machine.
Check the oil, coolant, grease, and tools.
Recover materials and parts as necessary.
Pay enough attention to safety.

 WARNING:

Some of the machine's parts are extremely heavy.
Use an appropriate lifting equipment for such parts.
For weights and procedures, see the Service Manual.

 WARNING:

Exhaust gases are toxic.
Always provide good ventilation when working indoors or in any other enclosed space.

 WARNING:

If the electrolytic battery solution freezes, it may explode.

Safety rules - Cab protective structure

CX220C SERIES 2 Standard model, TIER 3 level engine	
CX240C Crawler excavator-Mass excavator - TIER 3	LA

Cab protective structure

Modifying the cab main components is prohibited in order to protect the operator.

Prohibited items

- Modifications that reduce the strength of a platform that has a cab with a protective structure mounted on it. (Actions or modifications that reduce the functionality of the anchoring part at the left-rear of the cab)
- Modifications that effect the strength of the cab with a protective structure.

Modifications prohibited (red part)	All modifications (grinding, welding, drilling holes, removing, etc.) are prohibited.
Modifications permitted under conditions (gray part)	Removal of parts is prohibited. Bar welding and making holes (up to diameter 20 mm (0.787 in)) by drilling are possible.

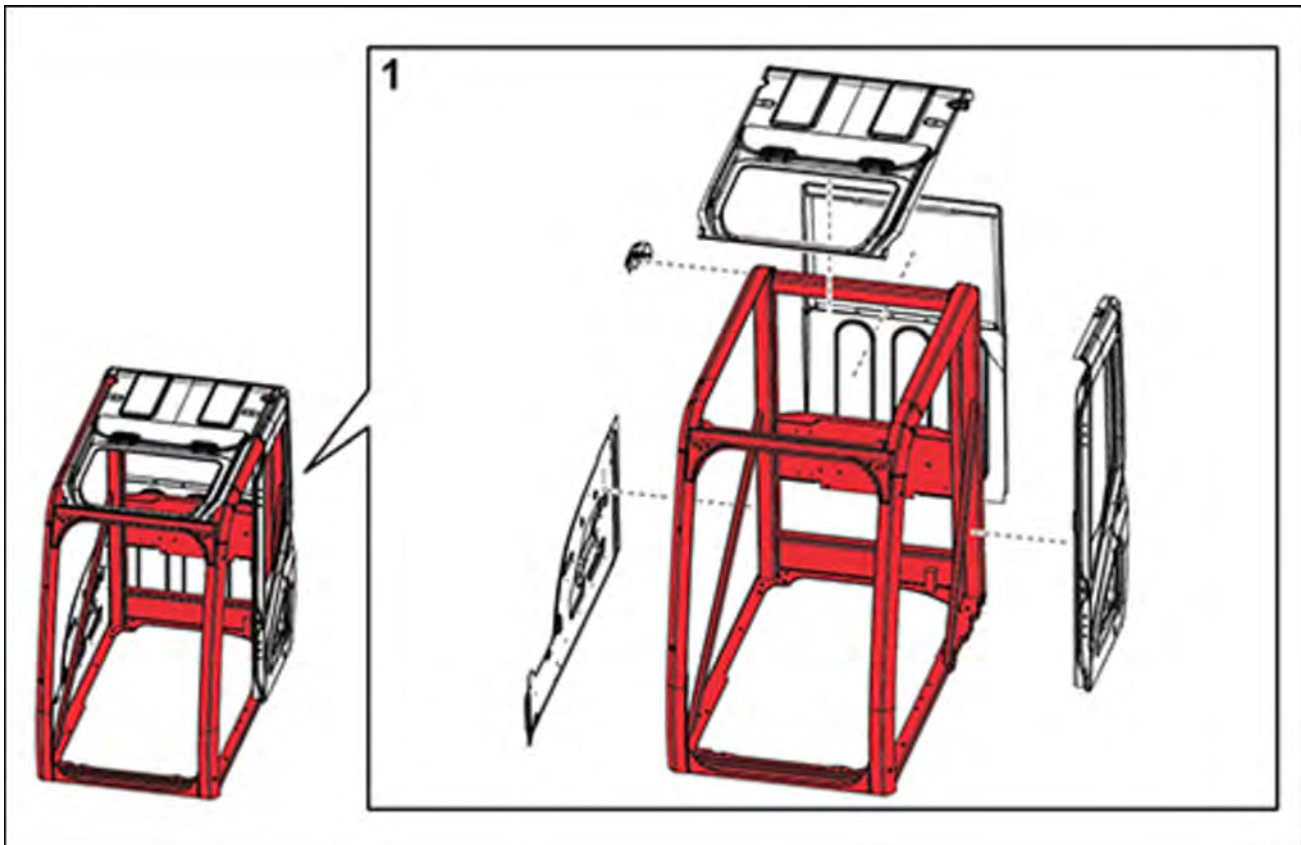

SMPH15CEX6544FA 1

Torque - Bolt and nut

CX220C SERIES 2 Standard model, TIER 3 level engine	
CX240C Crawler excavator-Mass excavator - TIER 3	LA

- Tighten alternating between left and right and top and bottom so that uniform tightening force is applied.

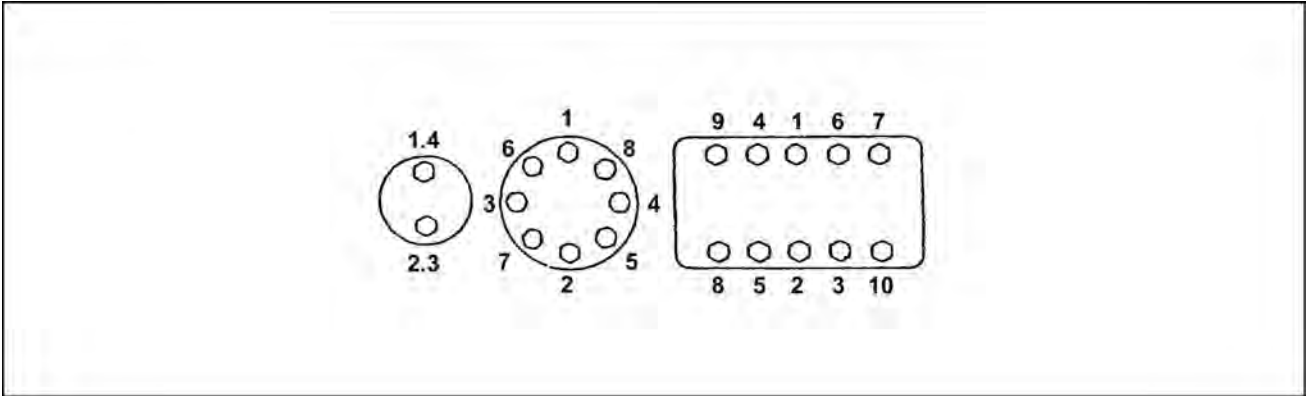

LPIL12CX0005EA 1

- If **LOCTITE®** was used on a removed bolt (there is something white sticking to the bolt when it is removed), clean the old **LOCTITE®** off with cleaning fluid, dry the bolt, then apply 2 - 3 drops of **LOCTITE®** to the thread section of the bolt.

Torque table

Bolt nominal diameter (size)		M6	M8	M10	M12	M14	M16	M18	M20
Hexagon bolt	Wrench	10 mm	13 mm	17 mm	19 mm	22 mm	24 mm	27 mm	30 mm
	Tightening torque	6.9 N·m (5.089 lb ft)	19.6 N·m (14.456 lb ft)	39.2 N·m (28.912 lb ft)	58.8 N·m (43.369 lb ft)	98.1 N·m (72.355 lb ft)	156.9 N·m (115.72 3 lb ft)	196.1 N·m (144.63 6 lb ft)	294.2 N·m (216.99 1 lb ft)
Hexagon socket head bolt	Wrench	5 mm	6 mm	8 mm	10 mm	12 mm	14 mm	14 mm	17 mm
	Tightening torque	8.8 N·m (6.491 lb ft)	21.6 N·m (15.931 lb ft)	42.1 N·m (31.051 lb ft)	78.5 N·m (57.899 lb ft)	117.7 N·m (86.811 lb ft)	176.5 N·m (130.18 0 lb ft)	245.2 N·m (180.85 0 lb ft)	343.2 N·m (253.13 1 lb ft)

Torque - Special torque settings

CX220C SERIES 2 Standard model, TIER 3 level engine	
CX240C Crawler excavator-Mass excavator - TIER 3	LA

Code	Retightening location		Bolt nominal diameter	Wrench	Tightening torque
1*	Travel motor		M16	24 mm	267 - 312 N·m (196.93 - 230.12 lb ft)
2*	Drive sprocket		M16	24 mm	267 - 312 N·m (196.93 - 230.12 lb ft)
3*	Take-up roller		M16	24 mm	267 - 312 N·m (196.93 - 230.12 lb ft)
4*	Upper roller		M20	30 mm	521 - 608 N·m (384.27 - 448.44 lb ft)
5*	Lower roller		M18	27 mm	371 - 432 N·m (273.64 - 318.63 lb ft)
6*	Track guard		M18	27 mm	400 - 462 N·m (295.02 - 340.75 lb ft)
7	Shoe		M20	30 mm	755 - 853 N·m (556.86 - 629.14 lb ft)
8	Counterweight		M33	50 mm	1862 - 2058 N·m (1373.34 - 1517.90 lb ft)
9	Turntable bearing		M20	30 mm	468 - 545 N·m (345.18 - 401.97 lb ft)
10*	Swing unit		M20	30 mm	539.4 - 629.6 N·m (397.84 - 464.37 lb ft)
11*	Engine	Mount	M16	24 mm	264.9 - 313.9 N·m (195.38 - 231.52 lb ft)
12*		Front bracket	M10	17 mm	63.8 - 73.6 N·m (47.06 - 54.28 lb ft)
13*		Rear bracket	M16	24 mm	205.9 - 247.1 N·m (151.86 - 182.25 lb ft)
14	Radiator		M16	24 mm	147.2 - 176.6 N·m (108.57 - 130.25 lb ft)
15*	Hydraulic pump	Pump	M20	17 mm hexagon socket head	367 - 496 N·m (270.69 - 365.83 lb ft)
16*	Hydraulic oil tank		M16	24 mm	232.4 - 276 N·m (171.41 - 203.57 lb ft)
17*	Fuel tank		M16	24 mm	232.4 - 276 N·m (171.41 - 203.57 lb ft)
18*	Control valve		M16	24 mm	267 - 312 N·m (196.93 - 230.12 lb ft)
19*	Center	Lock bar	M12	19 mm	88.3 - 107 N·m (65.13 - 78.92 lb ft)
20*	Joint	Joint	M12	19 mm	109 - 127 N·m (80.39 - 93.67 lb ft)
21	Cab		M16	24 mm	149 - 173 N·m (109.90 - 127.60 lb ft)
22			M10	17 mm	19.6 - 29.4 N·m (14.46 - 21.68 lb ft)

CAUTION:

- For items marked with *, always apply **LOCTITE® 262™** or the equivalent and tighten to the specified torque. The tightening torque in kgf·m is determined with $N \cdot m \div 9.8$ ($lbf \cdot ft \div 7.2$).

INTRODUCTION

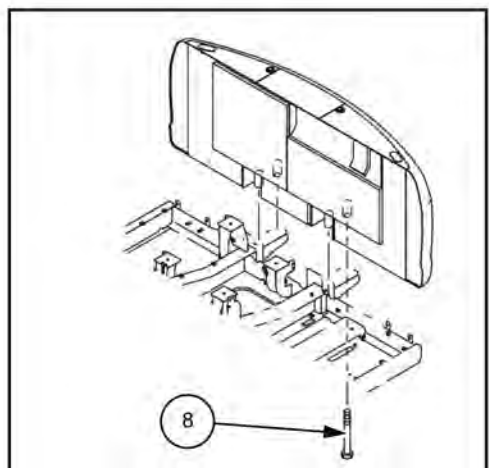
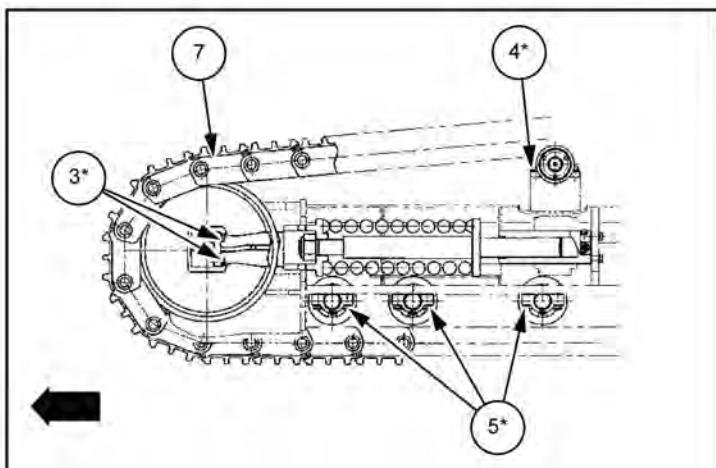
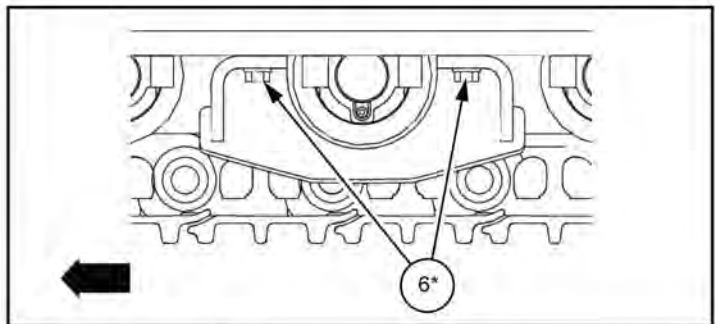
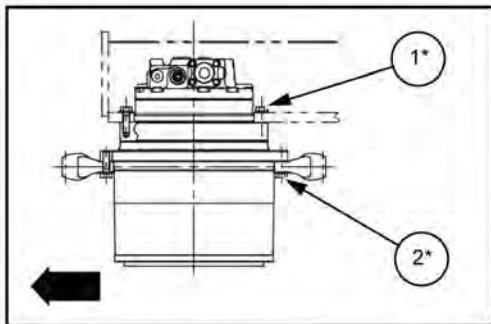
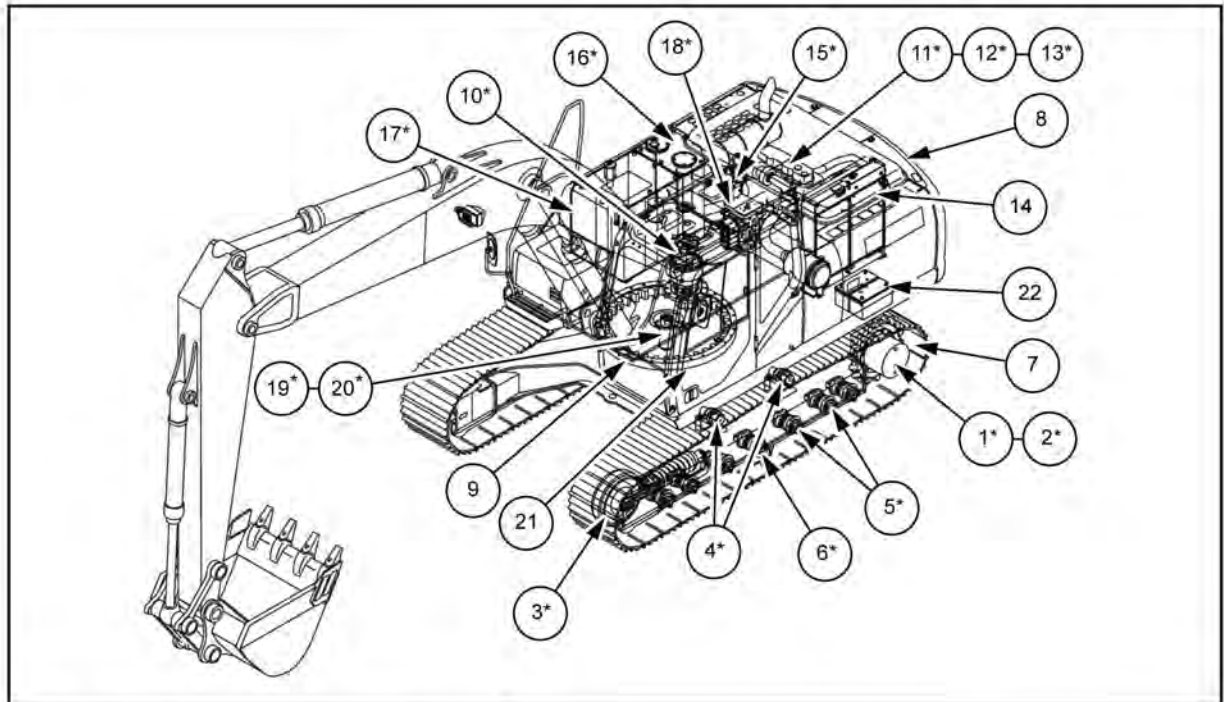

LPIL12CX00034HB 1

INTRODUCTION

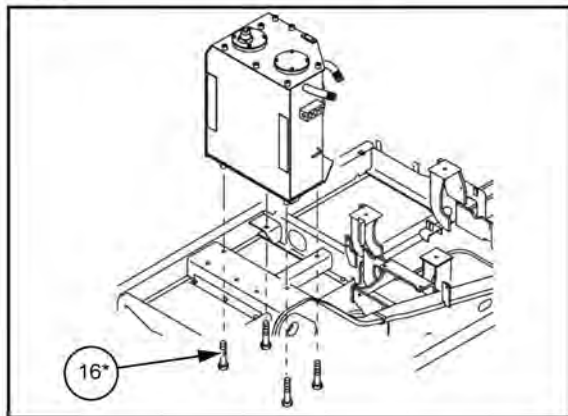
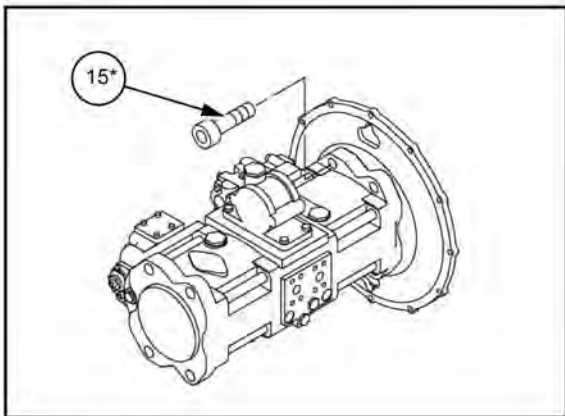
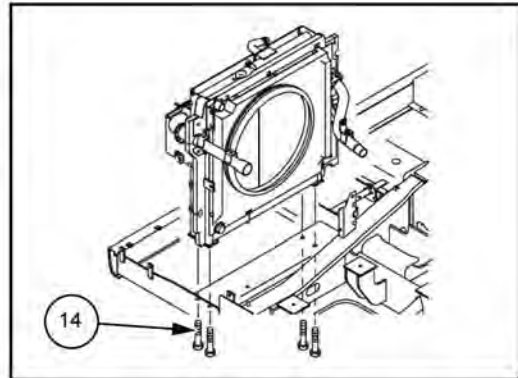
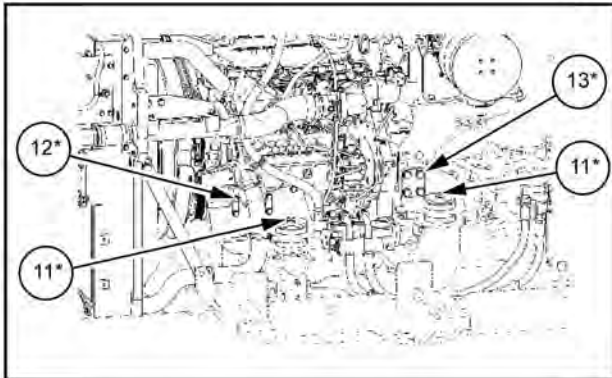
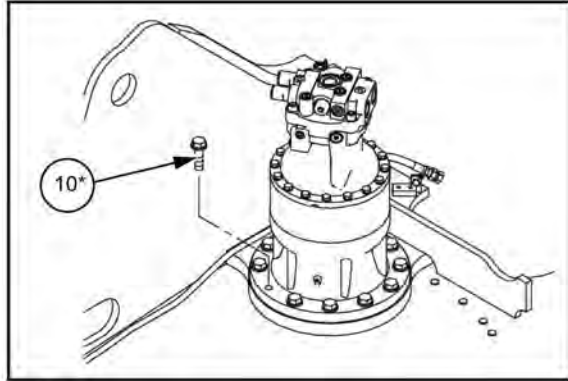
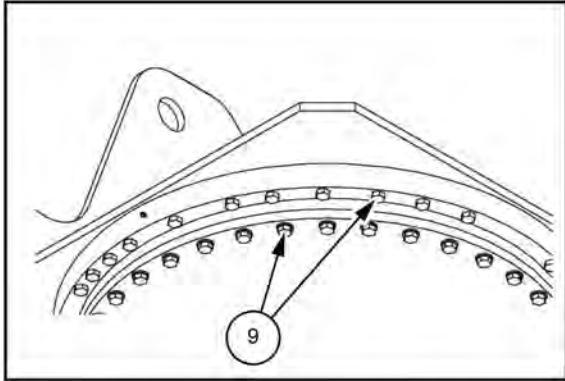

SMIL13CEX1312GB 2

INTRODUCTION

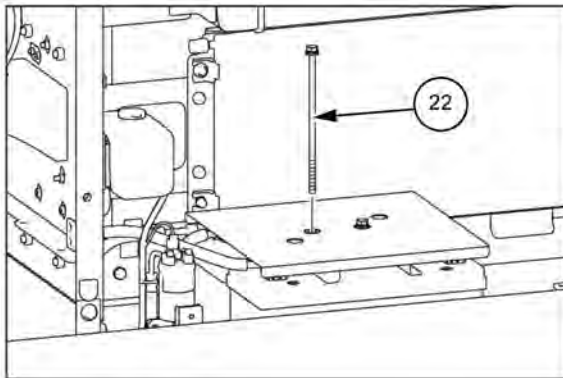
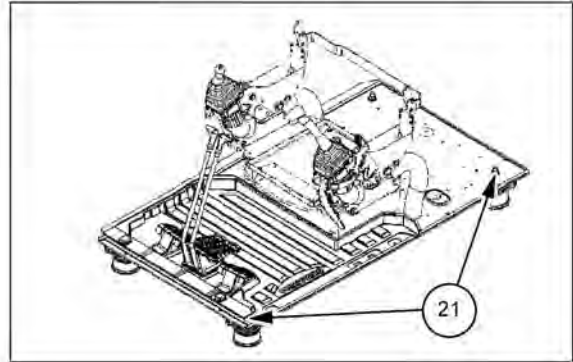
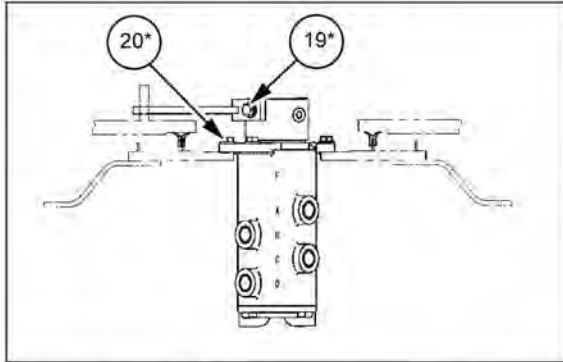
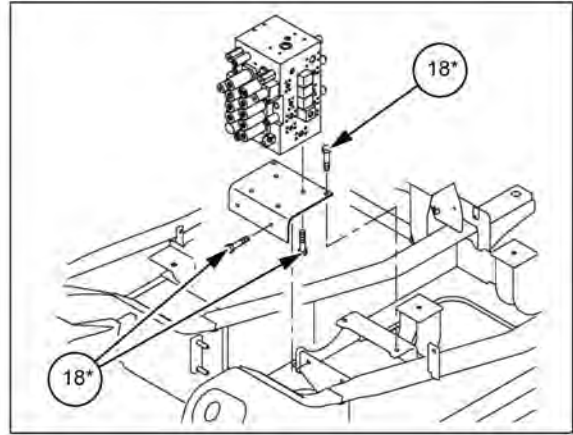
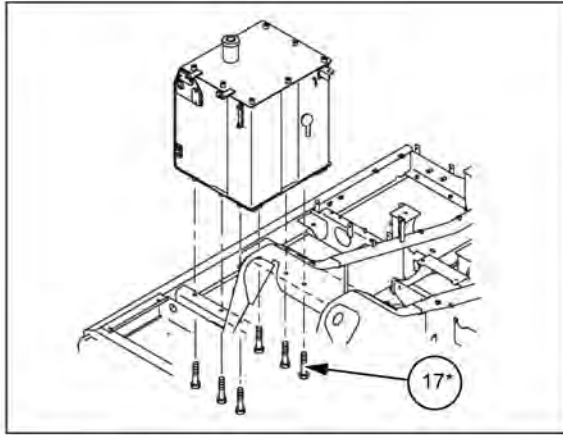

SML13CEX1313GB 3

Basic instructions - Shop and assembly

CX220C SERIES 2 Standard model, TIER 3 level engine	
CX240C Crawler excavator-Mass excavator - TIER 3	LA

Shimming

For each adjustment operation, select adjusting shims and measure the adjusting shims individually using a micrometer, then add up the recorded values. Do not rely on measuring the entire shimming set, which may be incorrect, or the rated value shown on each shim.

Rotating shaft seals

For correct rotating shaft seal installation, proceed as follows:

1. Before assembly, allow the seal to soak in the oil it will be sealing for at least thirty minutes.
2. Thoroughly clean the shaft and check that the working surface on the shaft is not damaged.
3. Position the sealing lip facing the fluid.

NOTE: With hydrodynamic lips, take into consideration the shaft rotation direction and position the grooves so that they will move the fluid towards the inner side of the seal.

4. Coat the sealing lip with a thin layer of lubricant (use oil rather than grease). Fill the gap between the sealing lip and the dust lip on double lip seals with grease.
5. Insert the seal in its seat and press down using a flat punch or seal installation tool. Do not tap the seal with a hammer or mallet.
6. While you insert the seal, check that the seal is perpendicular to the seat. When the seal settles, make sure that the seal makes contact with the thrust element, if required.
7. To prevent damage to the seal lip on the shaft, position a protective guard during installation operations.

O-ring seals

Lubricate the O-ring seals before you insert them in the seats. This will prevent the O-ring seals from overturning and twisting, which would jeopardize sealing efficiency.

Sealing compounds

Apply a sealing compound on the mating surfaces when specified by the procedure. Before you apply the sealing compound, prepare the surfaces as directed by the product container.

Spare parts

Only use CNH Original Parts or CASE CONSTRUCTION Original Parts.

Only genuine spare parts guarantee the same quality, duration, and safety as original parts, as they are the same parts that are assembled during standard production. Only CNH Original Parts or CASE CONSTRUCTION Original Parts can offer this guarantee.

When ordering spare parts, always provide the following information:

- Machine model (commercial name) and Product Identification Number (PIN)
- Part number of the ordered part, which can be found in the parts catalog

Protecting the electronic and/or electrical systems during charging and welding

To avoid damage to the electronic and/or electrical systems, always observe the following practices:

1. Never make or break any of the charging circuit connections when the engine is running, including the battery connections.
2. Never short any of the charging components to ground.
3. Always disconnect the ground cable from the battery before arc welding on the machine or on any machine attachment.
 - Position the welder ground clamp as close to the welding area as possible.
 - If you weld in close proximity to a computer module, then you should remove the module from the machine.
 - Never allow welding cables to lie on, near, or across any electrical wiring or electronic component while you weld.
4. Always disconnect the negative cable from the battery when charging the battery in the machine with a battery charger.

NOTICE: *If you must weld on the unit, you must disconnect the battery ground cable from the machine battery. The electronic monitoring system and charging system will be damaged if this is not done.*

5. Remove the battery ground cable. Reconnect the cable when you complete welding.

▲ WARNING

Battery acid causes burns. Batteries contain sulfuric acid.

Avoid contact with skin, eyes or clothing. Antidote (external): Flush with water. Antidote (eyes): flush with water for 15 minutes and seek medical attention immediately. Antidote (internal): Drink large quantities of water or milk. Do not induce vomiting. Seek medical attention immediately. Failure to comply could result in death or serious injury.

W0111A

Special tools

The special tools that CASE CONSTRUCTION suggests and illustrate in this manual have been specifically researched and designed for use with CASE CONSTRUCTION machines. The special tools are essential for reliable repair operations. The special tools are accurately built and rigorously tested to offer efficient and long-lasting operation.

By using these tools, repair personnel will benefit from:

- Operating in optimal technical conditions
- Obtaining the best results
- Saving time and effort
- Working in safe conditions

General specification

CX220C SERIES 2 Standard model, TIER 3 level engine	
CX240C Crawler excavator-Mass excavator - TIER 3	LA

Main data

Operating weight	20920 kg (46120.71 lb)
Engine output	117.3 kW (159.48 Hp) / 1800 RPM
Bucket capacity	Heaped 0.9 m³ (31.8 ft³) Leveled 0.61 m³ (21.54 ft³)

Performance

Standard weight	13.5 kN (3034.921 lb)
Swing speed	13.5 RPM
Travel speed	Low speed 3.4 km/h (2.1127 mph)
	High speed 5.6 km/h (3.4797 mph)
Maximum pulling force	188 kN (42264.08 lb)
Grade ability	70 % (35 °)
Ground pressure	45 kPa (7 psi) (600 mm (23.622 in) grouser shoe)
	37 kPa (5 psi) (800 mm (31.496 in) grouser shoe)

Main unit dimensions

Main unit length	4810 mm (189.370 in)
Main unit height	2800 mm (110.236 in)
Upper swing body width	2735 mm (107.677 in)
Cab width	1000 mm (39.370 in)
Main unit height	2750 mm (108.268 in)
Swing radius (rear end)	2750 mm (108.268 in)
Swing body rear end distance	2720 mm (107.087 in)
Swing body rear section bottom height	1040 mm (40.945 in)
Distance between tumblers	3370 mm (132.677 in)
Overall track length	4180 mm (164.567 in)
Overall track width	2800 mm (110.236 in)
Distance between tracks	2200 mm (86.614 in)
Track shoe width	600 mm (23.62 in) option: 800 mm (31.50 in)
Minimum ground clearance	440 mm (17.323 in) (to bottom of lower frame)

Engine

Name	Isuzu 4HK1X diesel engine
Model	4-cycle, water-cooled, overhead camshaft type, common rail system (electronic control), cooled EGR, with turbocharger
No. of cylinders - bore x stroke	4 - Ø115 mm (4.528 in) x 125 mm (4.921 in)
Total stroke volume	5.193 l (1.3718 US gal)
Maximum torque	606 N·m (446.96 lb ft) / 1500 RPM
Starter	24 V 5.0 kW reduction type
Charging generator	24 V 50 A AC type
Battery	12 V 92 A·h / 5 h x 2

Cooling system

Fan type	Ø650 mm (25.591 in), 7 blades, suction
Radiator	
Fin type	Wavy
Fin pitch	2.0 mm (0.07874 in)

INTRODUCTION

Oil cooler		
	Fin type	Wavy
	Fin pitch	2.0 mm (0.07874 in)
Intercooler		
	Fin type	Wavy
	Fin pitch	1.75 mm (0.06890 in)
Fuel cooler		
	Fin type	Wavy
	Fin pitch	2.0 mm (0.07874 in)

Upper side work system

Type	Backhoe attachment	
Components, dimensions, working dimensions		
	Standard bucket capacity	
	Heaped 0.9 m³ (31.8 ft³) (Leveled 0.61 m³ (21.5 ft³))	
	Arm type	Standard (STD/HD) 2.94 m (9.646 ft) Short (STD/HD) 2.40 m (7.874 ft)
	Arm length	2940 mm (115.748 in) 2400 mm (94.488 in)
	Bucket radius	1450 mm (57.087 in)
	Bucket wrist angle	177°
	Maximum digging radius	9900 mm (389.764 in) 9420 mm (370.866 in)
	Maximum digging radius at ground line	9730 mm (383.07 in) 9240 mm (363.78 in)
	Maximum digging depth	6650 mm (261.811 in) 6110 mm (240.551 in)
	Maximum vertical straight wall digging depth	5960 mm (234.646 in) 5500 mm (216.535 in)
	Maximum digging height	9610 mm (378.346 in) 9410 mm (370.472 in)
	Maximum dump height	6810 mm (268.110 in) 6590 mm (259.449 in)
	Minimum swing radius at front	3600 mm (141.732 in) 3600 mm (141.732 in)
	Height for minimum swing radius at front	7640 mm (300.787 in) 7700 mm (303.150 in)

Operating device

Operator's seat		
	Position	Left side
	Structure	Adjustable forward, back, up and down, reclining mechanism, with seat suspension
Cab		Sealed steel, type, all reinforced glass
Levers and pedals		
	For travel use	Lever and pedal type (hydraulic pilot type) x 2
	For operating machine use	Lever type (hydraulic pilot type) x 2
Instruments and switches		
Work mode switchover		3 modes (SP/H/A)

	Travel mode switchover	Low-speed/high-speed switch type
	One-touch idle	Knob switch type
	Engine emergency stop	Switch type
Monitor device		
	Machine status display (full color liquid crystal)	
	Work mode select status	SP/H/A
Instruments (full color liquid crystal)		
	Fuel gauge	Bar graph and indicator
	Engine coolant temperature gauge	Bar graph and indicator
	Hydraulic oil temperature gauge	Bar graph and indicator
	Hour meter	Digital type
Machine status and warnings (full color liquid crystal and warning alarm) * has warning alarm		
OVERHEAT (*) ALTERNATOR (*) ELEC PROBLEM (*) LOW FUEL (*) LOW OIL PRESS. (*) LOW COOLANT (*) ENG. PRE HEAT AUTO WARM UP AUR FILTER (*) SECURITY ON CHECK ENGINE (*) ENGINE STOP (*)		
Illumination equipment		

INTRODUCTION

Working light	Tank front surface	24V 70W x1
	Cab top	24V 70W x2 (option)
	Boom up	24V 70W x1
Interior light		24V 70W x1
Horn		Electric horn x2
Other		Wiper with intermittent function, window washer, air conditioner, clock, rear view mirrors (left and right, total of 2), DC converter, AM/FM radio, feed pump (option), rear view camera/side camera (option)

Swing units

Swing circle	Swing bearing type (with inner gear)
Swing hydraulic motor	Fixed displacement piston motor x 1
Reduction gear	Planetary gear 2-stage reduction gear
Swing parking brake	Mechanical lock (operational lever linkage type)

Undercarriage

Travel hydraulic motor	Variable displacement piston motor x2
Reduction gear	Planetary gear 2-stage reduction gear
Travel brake	Hydraulic lock
Parking brake	Mechanical lock (travel lever linkage type)
Track shoe	
Type	Assembly-type triple grouser shoe
No. of shoe plates (per side)	46
Shoe width	600 mm (23.622 in) (option 800 mm (31.496 in))
Grouser height	26 mm (1.024 in)
Link pitch	190 mm (7.480 in)
Roller	
No. of upper rollers (per side)	2
No. of lower rollers (per side)	7
Track belt tension adjuster	Grease cylinder type (with cushion spring)

Hydraulic equipment

Hydraulic device

Hydraulic pump drive type	Direct engine link (no transmission)
Hydraulic pump	
Type	Double variable displacement piston pump x 1 Gear pump x 1
Discharge volume	Piston pump 2 x 211 l/min (55.740 US gpm) Gear pump 18 l/min (4.755 US gpm)
Pump control method	Simultaneous output full-horsepower control
Set pressure of main relief valve	34.3 MPa (4975 psi) [37 MPa (5338 psi) for pressure boost]
Set pressure of overload relief valve	29.4 MPa (4264 psi) (boom down) 38.7 MPa (5613 psi) (other)

Control valve and cylinder

Control valve			
Model	Quadruple spool Quintuple spool	One-piece type x 1	
Operating method	Hydraulic pilot type: Travel, swing, and operating machine		
Cylinder	No. of cylinders x tube bore - rod diameter - stroke		
Boom cylinder	2 x Ø120 mm (4.724 in) - Ø85 mm (3.346 in) - 1255 mm (49.409 in)		

INTRODUCTION

Arm cylinder	1 x Ø140 mm (5.512 in) - Ø100 mm (3.937 in) - 1460 mm (57.480 in)
Bucket cylinder	1 x Ø120 mm (4.724 in) - Ø85 mm (3.346 in) - 1010 mm (39.764 in)

Filters

Hydraulic filters

Suction filter (inside tank)	105 µm
Return filter (inside tank)	10 µm
Pilot line filter (inside housing)	8 µm

Fuel filters

Main filter	2 µm
Pre-filter	5.5 µm

General specification - Main equipment

CX220C SERIES 2 Standard model, TIER 3 level engine	
CX240C Crawler excavator-Mass excavator - TIER 3	LA

Lower component

Travel unit

Manufacturer	KYB Corporation
Motor type	Variable displacement piston motor
	Automatic 2-speed switchover with parking brake
Intake amount	168.9 cm³/rev (10.31 in³/rev)
Operating pressure	34.3 MPa (4975 psi)
Operating flow	210.6 l/min (55.6346 US gpm)
Brake torque	32700 N·m (24118 lb ft) min. (including reduction gear)
Relief valve set pressure	35.3 MPa (5120 psi) at 40 l/min (10.57 US gpm)
Automatic 2-speed switch over pressure	25.8 MPa (3742 psi)
Reduction gear	
Reduction gear type	Planetary gear 2-stage reduction gear
Reduction ratio	43.246
Dry weight	263 kg (579.816 lb)

Take-up roller

Weight	96.4 kg (212.5256 lb)
--------	------------------------------

Upper roller

Weight	17.8 kg (39.2423 lb)
--------	-----------------------------

Lower roller

Weight	35.0 kg (77.1618 lb)
--------	-----------------------------

Recoil spring

Item	Weight	Quantity
Yoke	23.9 kg (52.6905 lb)	1
Sems B M16 x 50	0.5 kg (1.1023 lb)	4
Threaded rod	24.8 kg (54.6746 lb)	1
Groove height N M48	1.0 kg (2.2046 lb)	1
SP pin 8 x 80	0.1 kg (0.2205 lb)	1
Recoil spring	61.7 kg (136.0252 lb)	1
Grease cylinder assembly	28.4 kg (62.6113 lb)	1
Sems B M16 x 60	0.3 kg (0.6614 lb)	2
Assembly (total)	147.9 mm (5.8228 in)	
Mounting length of spring	576 mm (22.68 in)	

Shoe

	Weight or Quantity
600 grouser	1324 kg (2918.920 lb)
Link	1 set
Shoe	46
Bolt	184
Nut	184
800 grouser	1586 kg (3496.531 lb)
Link	1 set
Shoe	46
Bolt	184
Nut	184

Upper component

Swing unit

Swing motor assembly		
Swing motor		
Manufacturer	Toshiba Machine Co., Ltd.	
Motor type	Fixed displacement piston motor	
	With parking brake	
Intake amount	151 cm³/rev (9.21 in³/rev)	
Operating pressure	29.4 MPa (4264 psi)	
Operating flow	210.6 l/min (55.6346 US gpm)	
Mechanical brake torque	821.5 N·m (605.907 lb ft) min.	
Brake off pressure	3.2 MPa (464 psi) or less	
Relief valve set pressure	29.4 MPa (4264 psi)	
Swing reduction gear		
Reduction gear type	Planetary reduction gear	
Reduction ratio	16.757	
Dry weight	227 kg (500.449 lb)	
Turntable bearing		
No. of teeth	92	
Weight	244 kg (537.928 lb)	
Counterweight		
Weight	4100 kg (9038.953 lb)	

Engine-related

Engine

Engine model name	Isuzu 4HK1X diesel engine
Engine type	4-cycle, water-cooled, overhead camshaft type straight cylinder, direct fuel injection type (electronic control)
Number of cylinders-bore-stroke	4 - \varnothing 115 mm (4.53 in) - 125 mm (4.92 in)
Total displacement	5.193 l (1.3718 US gal)
Compression ratio	17.5
Rated output	117.3 kW (159.48 Hp) / 1800 RPM
Maximum torque	606 N·m (446.96 lb ft) / about 1500 RPM
Fuel consumption ratio	*** g/kWh at 1800 RPM
Engine dry weight	About 480 kg (1058.219 lb)
Engine dimension	L 1020.4 mm (40.1732 in) - W 829.0 mm (32.638 in) - H 1011.8 mm (39.8346 in)
Cooling fan	\varnothing 650 mm (25.591 in) - suction type - 7 vanes, plastic
	With bell mouth-type fan guide
Pulley ratio	0.85 (reduction)
Charging generator	24 V 50 A AC type
Starter motor	24 V 5 kW (6.8 Hp) reduction type
Coolant capacity	14.0 l (14.000 US gal)
Oil pan capacity	Max: 20.5 l (5.416 US gal) Min: 13.0 l (3.434 US gal) (not including oil filter)
Direction of rotation	Right (viewed from fan side)
	Compliant with JISD 0006-2010

Muffler

Manufacturer	Sankei Giken Kogyo Co., Ltd.
Type	D 280 x 700 L
Maximum displacement	31800 L/min (8400.7 US gpm)
Weight	15 kg (33.0693 lb)

INTRODUCTION

Air cleaner (double element)

Manufacturer	Nippon Donaldson, Ltd.
Element (outer)	
Element (inner)	
Weight	7.5 kg (16.5347 lb)

Radiator

Manufacturer	Zhejiang Yinlun Machinery Co., Ltf.	
Oil cooler	Weight	40.6 kg (89.5077 lb)
	Oil volume	10.35 l (10.350 US gal)
Radiator	Weight	16.6 kg (36.5967 lb)
	Coolant capacity	9.98 l (9.980 US gal)
Air cooler	Weight	9.5 kg (20.9439 lb)
	Capacity	-
Fuel cooler	Weight	1.2 kg (2.6455 lb)
	Capacity	0.34 l (0.340 US gal)
Total weight	*** kg (***) lb	

Hydraulic device

Hydraulic pump

Manufacturer	Kawasaki Heavy Industries, Ltd.	
Main pump		
Pump type	Double variable displacement piston pump	
Displacement capacity	118.5 cm³/rev (7.231 in³/rev) x 2	
Operating pressure	Rated	34.3 MPa (4975 psi)
	Maximum	36.8 MPa (5337.84 psi)
Input revolution speed	1800 RPM	
Maximum discharge flow	211 l/min (55.740 US gpm) x 2 (at 1800 RPM)	
Pilot pump		
Pump type	Gear pump	
Displacement capacity	10 cm³/rev (0.61 in³/rev)	
Operating pressure	3.92 MPa (569 psi)	
Maximum discharge flow	18 l/min (4.76 US gpm) (at 1800 RPM)	
Control method	Hydraulic simultaneous constant output control	
	Maximum flow adjustment control through external commands (negative control)	
	Setting through external command milli-amp	
Dry weight	Horsepower adjustment control	
	136.4 kg (300.7105 lb)	

Control-related

Control valve

Manufacturer	KYB Corporation	
Maximum flow	213 l/min (56.269 US gpm) (at 1800 RPM)	
Overload set pressure	29.4 MPa (4264 psi) boom down	
	38.7 MPa (5613 psi) other	
Main relief set pressure	34.3 MPa (4975 psi)	
	(at boosting)	36.8 MPa (5338 psi)
Foot relief set pressure	2.55 MPa (370 psi)	
Function	Straight travel circuit	
	Boom-up/arm 2 pumps internal flow	
	Boom and arm load holding circuit	
	Boom-down regenerative circuit	

INTRODUCTION

	Bucket-close regenerative circuit
	Arm-in forced regenerative circuit
	Swing priority variable orifice (for arm operation)
	2 pumps flow
	Variable foot relief
Weight	200 kg (440.925 lb)

Solenoid valve (5 stack)

Manufacturer	Yuken Kogyo Co., Ltd.	
Valve specifications		
Maximum flow	P→B 25 l/min (6.604 US gpm) Other 5 l/min (1.321 US gpm)	
Rated pressure	4.5 MPa (652 psi)	
Port size	P.T.B port	G3/8
	C1, C2, C3, C4, C5 ports	G1/4
Solenoid specifications		
Operating voltage	DC 20 - 32 V	
Power consumption	17 W max.	
Weight	6.7 kg (14.7710 lb)	

Valve for left/right operations

Manufacturer	Kawasaki Heavy Industries, Ltd.	
Operating pressure	3.92 MPa (569 psi)	
Secondary pressure	0.64 - 2.45 MPa (92.8320 - 355 psi) primary short type	
Operating angle	1,3 port	19 °
	2,4 port	25 °
Weight	1.9 kg (4.1888 lb)	

Valve for travel operation

Manufacturer	Kawasaki Heavy Industries, Ltd.	
Operating pressure	3.92 MPa (569 psi)	
Secondary pressure	0.64 - 2.45 MPa (92.8320 - 355 psi) primary short type	
Operating angle	12.4 °	
Weight	5.5 kg (12.1254 lb)	

Remote control valve for option operations

Manufacturer	Nishina Industrial Co., Ltd.	
Operating pressure	39.2 bar (568.400 psi)	
Secondary pressure	6.4 - 24.5 bar (92.800 - 355.250 psi) primary short type	
Operating angle	11.4 ° – 12.6 °	
Port size	P, T, A, B, C1, C2 G1/4	
Weight	1.7 kg (3.748 lb)	

Remote control valve characteristic diagram

Operation remote control valve control diagram

Ports 1, 3

- A. Secondary pressure [MPa (psi)]
- B. Push rod stroke [mm (in)]
- C. Operating angle [deg.]
- 1 Secondary pressure

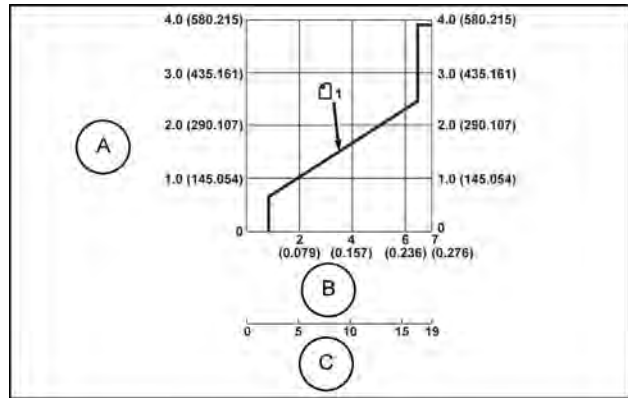

SMIL14CEX0416AB 1

Ports 2, 4

- A. Secondary pressure [MPa (psi)]
- B. Push rod stroke [mm (in)]
- C. Operating angle [deg.]
- 1 Secondary pressure

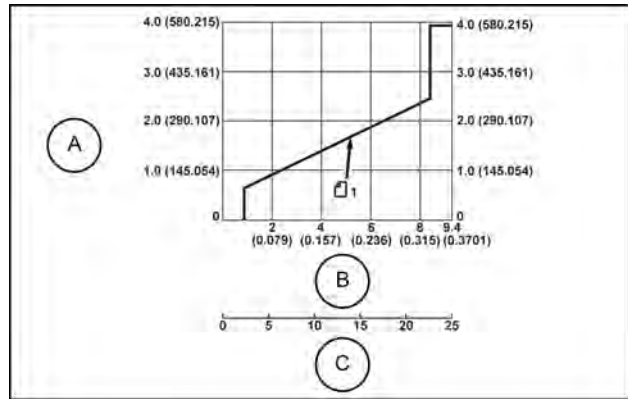

SMIL14CEX0418AB 2

Travel remote control valve control diagram

- A. Secondary pressure [MPa (psi)]
- B. Push rod stroke [mm (in)]
- C. Pedal operating angle [deg.]
- 1 Secondary pressure

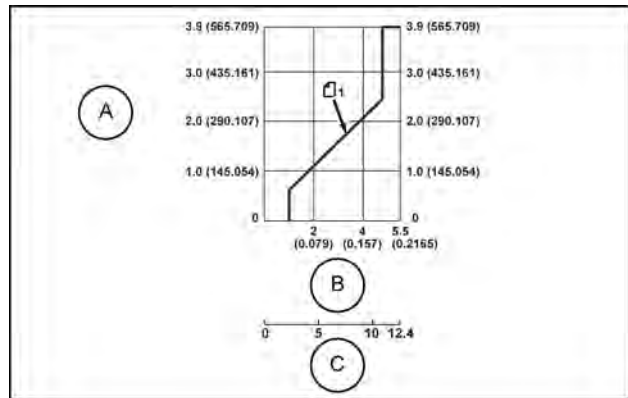

SMIL14CEX0423AB 3

Option remote control valve control diagram

- A. Secondary pressure [MPa (psi)]
- B. Operating angle [deg.]
- 1 Secondary pressure

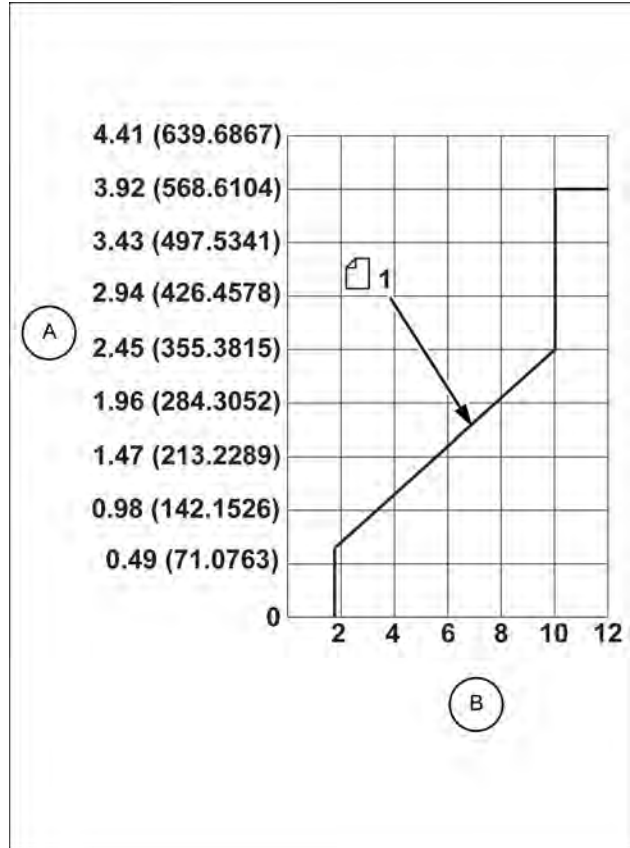

SML15CEX1698BB 4

Cushion valve (heat circuit, with shuttle valve)

Manufacturer	Yanagisawa Seiki MFG. Co., Ltd.
Port size	G3/8 (A - P ports)
	G1/4 (Q - V ports)
Weight	12.5 kg (27.5578 lb)

Center joint

Operating pressure	High-pressure passage (ABCD)	34.3 MPa (4975 psi)
	Drain port (E)	0.5 MPa (73 psi)
	Pilot port (F)	3.9 MPa (566 psi)
Flow	High-pressure passage (ABCD)	234 l/min (61.816 US gpm)
	Drain port (E)	10 l/min (2.642 US gpm)
	Pilot port (F)	21 l/min (5.548 US gpm)
Port A	Forward right	G3/4
Port B	Forward left	G3/4
Port C	Backward right	G3/4
Port D	Backward left	G3/4
Port E	Drain port	G1/2
Port F	Pilot port	G1/4
Weight		30 kg (66.139 lb)

Thanks for your reading.

Please click here to download complete manual instantly.

And can also choose other manuals.

Feel free --->write to me with any questions.

Our service email:

manuals007@hotmail.com