

# **CX210D** Crawler Excavator

## SERVICE MANUAL

Part number 47996199

English

March 2016

© 2016 CNH Industrial Italia S.p.A. All Rights Reserved.

**CASE**  
CONSTRUCTION



## **SERVICE MANUAL**

**CX210D Crawler excavators LC version (TIER 4 FINAL) - EU Market**

# Contents

---

## INTRODUCTION

Engine.....	10
[10.001] Engine and crankcase .....	10.1
[10.102] Pan and covers .....	10.2
[10.106] Valve drive and gears .....	10.3
[10.101] Cylinder heads .....	10.4
[10.105] Connecting rods and pistons.....	10.5
[10.103] Crankshaft and flywheel.....	10.6
[10.216] Fuel tanks .....	10.7
[10.206] Fuel filters .....	10.8
[10.218] Fuel injection system.....	10.9
[10.202] Air cleaners and lines .....	10.10
[10.250] Turbocharger and lines.....	10.11
[10.254] Intake and exhaust manifolds and muffler .....	10.12
[10.500] Selective Catalytic Reduction (SCR) exhaust treatment.....	10.13
[10.501] Exhaust Gas Recirculation (EGR) exhaust treatment.....	10.14
[10.400] Engine cooling system .....	10.15
[10.414] Fan and drive .....	10.16
[10.310] Aftercooler.....	10.17
[10.304] Engine lubrication system.....	10.18
Hydraulic systems.....	35
[35.000] Hydraulic systems.....	35.1
[35.300] Reservoir, cooler, and filters.....	35.2
[35.106] Variable displacement pump .....	35.3
[35.102] Pump control valves.....	35.4
[35.359] Main control valve.....	35.5
[35.357] Pilot system .....	35.6

[35.355] Hydraulic hand control .....	35.7
[35.356] Hydraulic foot control.....	35.8
[35.352] Hydraulic swing system .....	35.9
[35.353] Hydraulic travel system .....	35.10
[35.354] Hydraulic central joint .....	35.11
[35.736] Boom hydraulic system .....	35.12
[35.737] Dipper hydraulic system.....	35.13
[35.738] Excavator and backhoe bucket hydraulic system.....	35.14
[35.360] Hammer and rotating bucket hydraulic system .....	35.15
<b>Frames and ballasting .....</b>	<b>39</b>
[39.140] Ballasts and supports .....	39.1
<b>Tracks and track suspension .....</b>	<b>48</b>
[48.130] Track frame and driving wheels.....	48.1
[48.100] Tracks .....	48.2
[48.134] Track tension units .....	48.3
[48.138] Track rollers .....	48.4
<b>Cab climate control .....</b>	<b>50</b>
[50.100] Heating .....	50.1
[50.200] Air conditioning.....	50.2
<b>Electrical systems .....</b>	<b>55</b>
[55.000] Electrical system .....	55.1
[55.100] Harnesses and connectors.....	55.2
[55.525] Cab engine controls.....	55.3
[55.015] Engine control system.....	55.4
[55.201] Engine starting system .....	55.5
[55.301] Alternator.....	55.6
[55.302] Battery.....	55.7
[55.202] Cold start aid .....	55.8

[55.011] Fuel tank system .....	55.9
[55.010] Fuel injection system .....	55.10
[55.014] Engine intake and exhaust system.....	55.11
[55.988] Selective Catalytic Reduction (SCR) electrical system .....	55.12
[55.989] Exhaust Gas Recirculation (EGR) electrical system .....	55.13
[55.012] Engine cooling system .....	55.14
[55.013] Engine oil system .....	55.15
[55.640] Electronic modules .....	55.16
[55.512] Cab controls.....	55.17
[55.036] Hydraulic system control .....	55.18
[55.051] Cab Heating, Ventilation, and Air-Conditioning (HVAC) controls.....	55.19
[55.050] Heating, Ventilation, and Air-Conditioning (HVAC) control system.....	55.20
[55.524] Cab controls (Lift arm, Boom, Dipper, Bucket).....	55.21
[55.416] Swing control system .....	55.22
[55.417] Travel control system .....	55.23
[55.530] Camera.....	55.24
[55.518] Wiper and washer system.....	55.25
[55.404] External lighting .....	55.26
[55.514] Cab lighting .....	55.27
[55.408] Warning indicators, alarms, and instruments .....	55.28
[55.992] Anti-theft system .....	55.29
[55.DTC] FAULT CODES.....	55.30
<b>Booms, dippers, and buckets .....</b>	<b>84</b>
[84.910] Boom .....	84.1
[84.912] Dipper arm .....	84.2
[84.100] Bucket.....	84.3
<b>Platform, cab, bodywork, and decals .....</b>	<b>90</b>
[90.150] Cab.....	90.1

[90.156] Cab glazing .....	90.2
[90.118] Protections and footboards.....	90.3
[90.114] Operator protections .....	90.4
[90.120] Mechanically-adjusted operator seat.....	90.5
[90.100] Engine hood and panels .....	90.6
[90.116] Fenders and guards.....	90.7





## **INTRODUCTION**



# Contents

---

## INTRODUCTION

Foreword - Important notice regarding equipment servicing .....	3
Safety rules .....	4
Safety rules – General information .....	5
Safety rules – Personal safety .....	6
Safety rules – ROPS judgment .....	8
Safety rules - Ecology and the environment .....	11
Torque – Bolt and nut .....	12
Torque - Special torque setting .....	13
Basic instructions - Shop and assembly .....	17
Hydraulic contamination .....	19
General specification .....	20
General specification - Main equipment .....	25
Weight .....	35
Dimension .....	38
Capacities and fluids .....	41
Conversion factors .....	45
Abbreviation .....	57
Product identification .....	60
Product identification - Machine orientation .....	63

---

## **Foreword - Important notice regarding equipment servicing**

All repair and maintenance work listed in this manual must be carried out only by qualified dealership personnel, strictly complying with the instructions given, and using, whenever possible, the special tools.

Anyone who performs repair and maintenance operations without complying with the procedures provided herein shall be responsible for any subsequent damages.

The manufacturer and all the organizations of its distribution chain, including - without limitation - national, regional, or local dealers, reject any responsibility for damages caused by parts and/or components not approved by the manufacturer, including those used for the servicing or repair of the product manufactured or marketed by the manufacturer. In any case, no warranty is given or attributed on the product manufactured or marketed by the manufacturer in case of damages caused by parts and/or components not approved by the manufacturer.

The manufacturer reserves the right to make improvements in design and changes in specifications at any time without notice and without incurring any obligation to install them on units previously sold. Specifications, descriptions, and illustrative material herein are as accurate as known at time of publication but are subject to change without notice.

In case of questions, refer to your CASE CONSTRUCTION Sales and Service Networks.

## Safety rules

### Personal safety





This is the safety alert symbol. It is used to alert you to potential personal injury hazards. Obey all safety messages that follow this symbol to avoid possible death or injury.

Throughout this manual you will find the signal words DANGER, WARNING, and CAUTION followed by special instructions. These precautions are intended for the personal safety of you and those working with you.

Read and understand all the safety messages in this manual before you operate or service the machine.

 DANGER indicates a hazardous situation that, if not avoided, will result in death or serious injury.

 WARNING indicates a hazardous situation that, if not avoided, could result in death or serious injury.

 CAUTION indicates a hazardous situation that, if not avoided, could result in minor or moderate injury.

**FAILURE TO FOLLOW DANGER, WARNING, AND CAUTION MESSAGES COULD RESULT IN DEATH OR SERIOUS INJURY.**

### Machine safety

**NOTICE:** Notice indicates a situation that, if not avoided, could result in machine or property damage.

Throughout this manual you will find the signal word Notice followed by special instructions to prevent machine or property damage. The word Notice is used to address practices not related to personal safety.

### Information

**NOTE:** Note indicates additional information that clarifies steps, procedures, or other information in this manual.

Throughout this manual you will find the word Note followed by additional information about a step, procedure, or other information in the manual. The word Note is not intended to address personal safety or property damage.

## **Safety rules – General information**

### **Cleaning**

Clean the metal parts with cleaning solution that meets the standard and steam cleaning. (except for bearings)

After cleaning, dry well, and inject oil in all parts.

Also inject oil into the bearings after drying.

### **Inspection**

When disassembling parts, check all the parts.

If there are any worn or damaged parts, replace them.

Inspect carefully to prevent initial breakdowns.

### **Bearing**

Replace any loose bearings.

Air dry bearings before installing them.

### **Needle bearing**

When inserting needle bearings, be very careful not to damage them.

Apply grease to the section where the needle bearing will be inserted.

### **Gear**

Check that there is no wear and no damage.

### **Oil seal, O-ring, gasket**

Always install new oil seals, O-rings, and gaskets.

Apply grease to sections where oil seals and O-rings will be inserted.

### **Shaft**

Check that there is no wear and no damage.

Check the bearings and check for damaged oil seals on the shaft.

### **Service parts**

Install CASE CONSTRUCTION genuine service parts.

When placing an order, check the parts catalog. It contains the CASE CONSTRUCTION genuine part numbers.

Any breakdowns arising from the installation of non-genuine parts are not covered by the warranty.

### **Lubricants (fuel, hydraulic oil)**

Use the oil from the specified company or specified in the operator's manual or service Manual.

Any breakdowns arising from any fuel or hydraulic oil other than those specified are not covered by the warranty.

## Safety rules – Personal safety

 **WARNING:**

This symbol indicates a precaution.  
It gives information concerning the safety of the operator and those in the surroundings.  
Read and understand these precautions thoroughly before performing the work.

Always comply with warnings and precautions so as to avoid any accidents.

This section covers information related to overall safety.

Check whether all warning labels are in place.

Additional labels can be ordered from Service Parts.

 **WARNING:**

Read the operator's manual to gain a thorough understanding of machine control operations.

 **WARNING:**

Perform any machine operations from the seating position.  
Any other method may cause severe injuries.

 **WARNING:**

Only the one operator is to ride on the machine. No one else is to ride on it.

 **WARNING:**

Check the safety messages in the operator's manual before starting the engine.  
Check all the warning labels on the machine.  
Check that no one is within the machine's operating range.  
Check the operating methods in a safe location before starting the actual work.  
Understand the machine operations well, then operate in compliance with all service-related laws and regulations.  
The operator's manual can be purchased at your CASE CONSTRUCTION dealer.

 **WARNING:**

Working with sloppy clothes or clothes with which safety cannot be ensured leads to damage to the machine and injury to the operator.  
Always wear clothes that ensures safety.  
In order to work more safely, it is recommended to wear additional safety equipment.  
Helmet, safety shoes, ear protection, goggles, work clothes, and gloves

 **WARNING:**

Pay careful attention when working with the engine running.

 **WARNING:**

Check hydraulic equipment.  
Work according to the procedure.  
Do not change the procedure.

## INTRODUCTION

 WARNING:

Check that there is no one in the surroundings before draining the pressure from hydraulic circuits during machine hydraulic cylinder inspection.

 WARNING:

Use gloves when handling high-temperature parts.

 WARNING:

Bring the lower parts or attachments in contact with the ground before inspecting or repairing them.

 WARNING:

Check that hoses and tubes are securely connected.  
If there is any damage to a hose or tube, replace it.  
Do not check for oil leaks by hand. Use cardboard or wood.

 WARNING:

When removing an attachment pin or other hardened pin, use a hammer that has a soft head.

 WARNING:

Wear eye protection when using a hammer to install a pin or when working with a grinder.  
At this time, use goggles or eye protectors that meet standards.

 WARNING:

Park the machine in a safe location when repairing or inspecting it.

 WARNING:

Use work site protection when repairing the machine.  
Check the oil, coolant, grease, and tools.  
Recover materials and parts as necessary.  
Pay enough attention to safety.

 WARNING:

Some of the machine's parts are extremely heavy.  
Use an appropriate lifting equipment for such parts.  
For weights and procedures, see the Service Manual.

 WARNING:

Exhaust gases are toxic.  
Always provide good ventilation when working indoors or in any other enclosed space.

 WARNING:

If the electrolytic battery solution freezes, it may explode.

## Safety rules – ROPS judgment

### 1. Purpose

Judge whether or not the model is compliant with ROPS by the ROPS criteria.

Compliance with ROPS is highly dependent on its deadweight and boom.

The model has passed the ROPS test for its deadweight with all selectable options installed (as of 2014).

However, the judgment is required because its deadweight or boom position may go beyond the assumption depending on derivative or order conditions.

### 2. ROPS criteria

#### Weight

For each class, the following weight shall not be exceeded.

If the weight is exceeded, a cab may become damaged in case of a rollover, causing the operator to die or become severely disabled.

It is not applicable beyond the criterion.

The ROPS-compliant model shall not exceed the weight shown in the table.

(The following weight is shown on the decal in the ROPS cab.)

Gross body weight	Class
20500 kg (45194.76 lb) or less	CX130D
	CX160D
	CX180D
32000 kg (70547.92 lb) or less	CX210D
	CX230D
	CX250D
	CX300D

#### Boom position

##### Warning

- If you make such modification as lowers the boom position, ROPS is not applicable.
- Consultation with us is required whenever it is assumed that the boom position is lowered by modification.
- The range of change in the boom position cannot be determined uniformly.

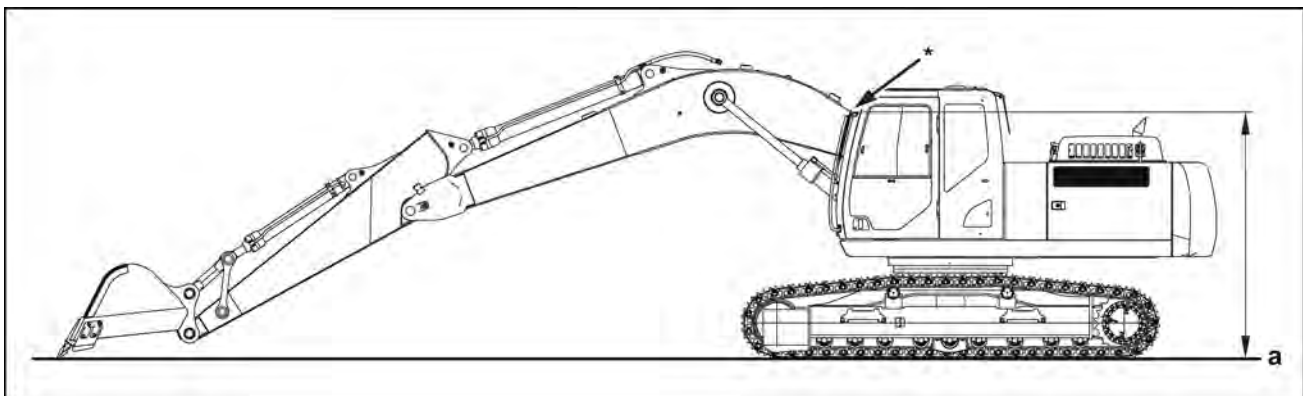

SMIL14CEX2001EA 1

(a) Ground point

It is not applicable if the position overlapping with a cab on the side view (mark \* in the figure) is lowered significantly as compared with the standard model (standard arm), within the maximum digging radius with the bucket tip on the surface of the ground.

Moreover, it cannot be said that the 24-ton model, close to the limit weight, with a cab that can bear up to 31-tons and the 21-ton model with the same cab are the same in the degree of influence.

### 3. Prohibitions

- Such modification as reduces the strength of the platform where the ROPS cab is installed. (Such action or modification as reduces the function of the retaining anchor in the left rear of the cab)
- Such modification as affects the ROPS strength of the ROPS cab.

Modification prohibited (Red components)	All changes (grinding, welding, drilling, removal, etc.) are prohibited.
Conditional modification permitted (Gray components)	Removal of components is prohibited. Welding and drilling of bars (limited to <b>20 mm (0.79 in)</b> or less in diameter) are allowed.

### Cab (CX130D/CX160D/CX180D)

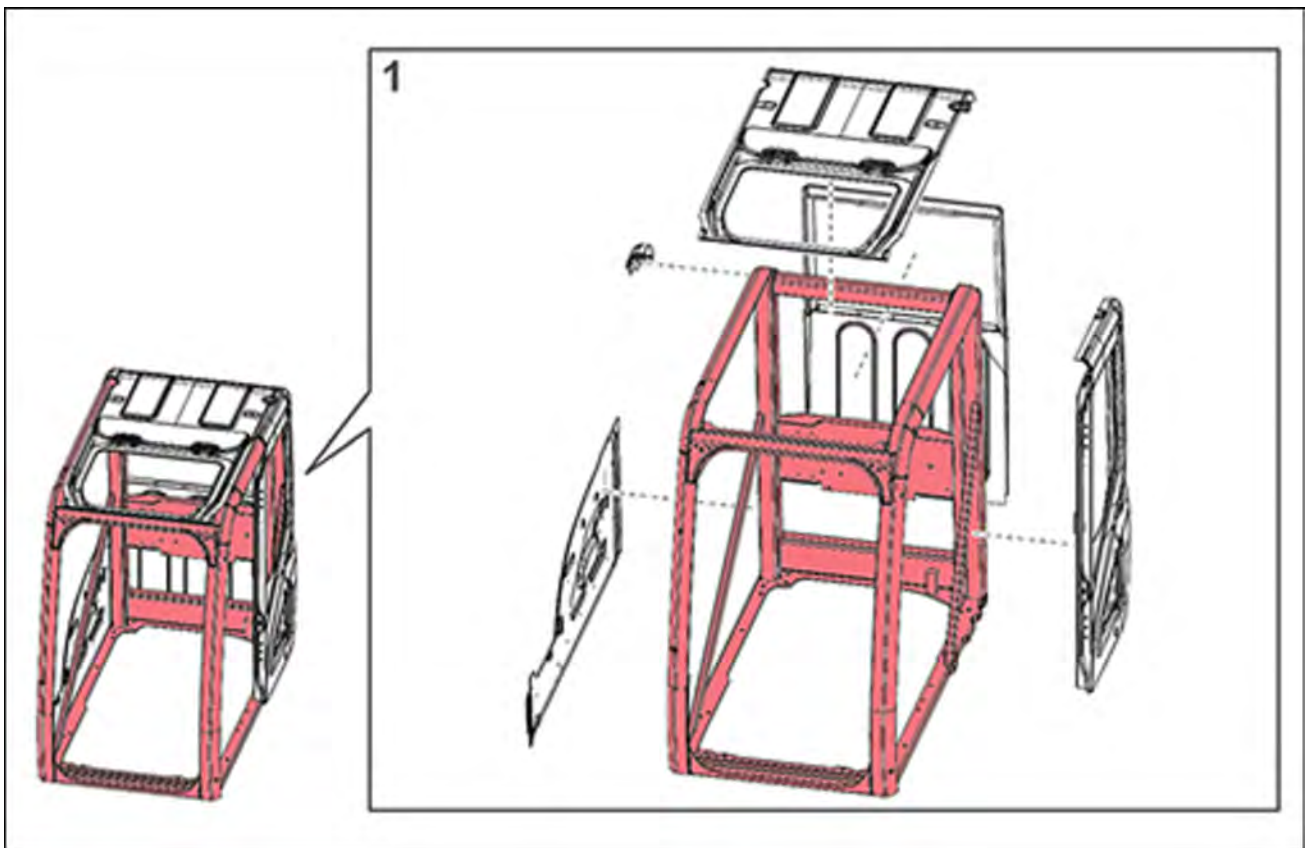

SMPH15CEX5805FA 2



**Cab (CX210D/CX230D/CX250D/CX300D)**

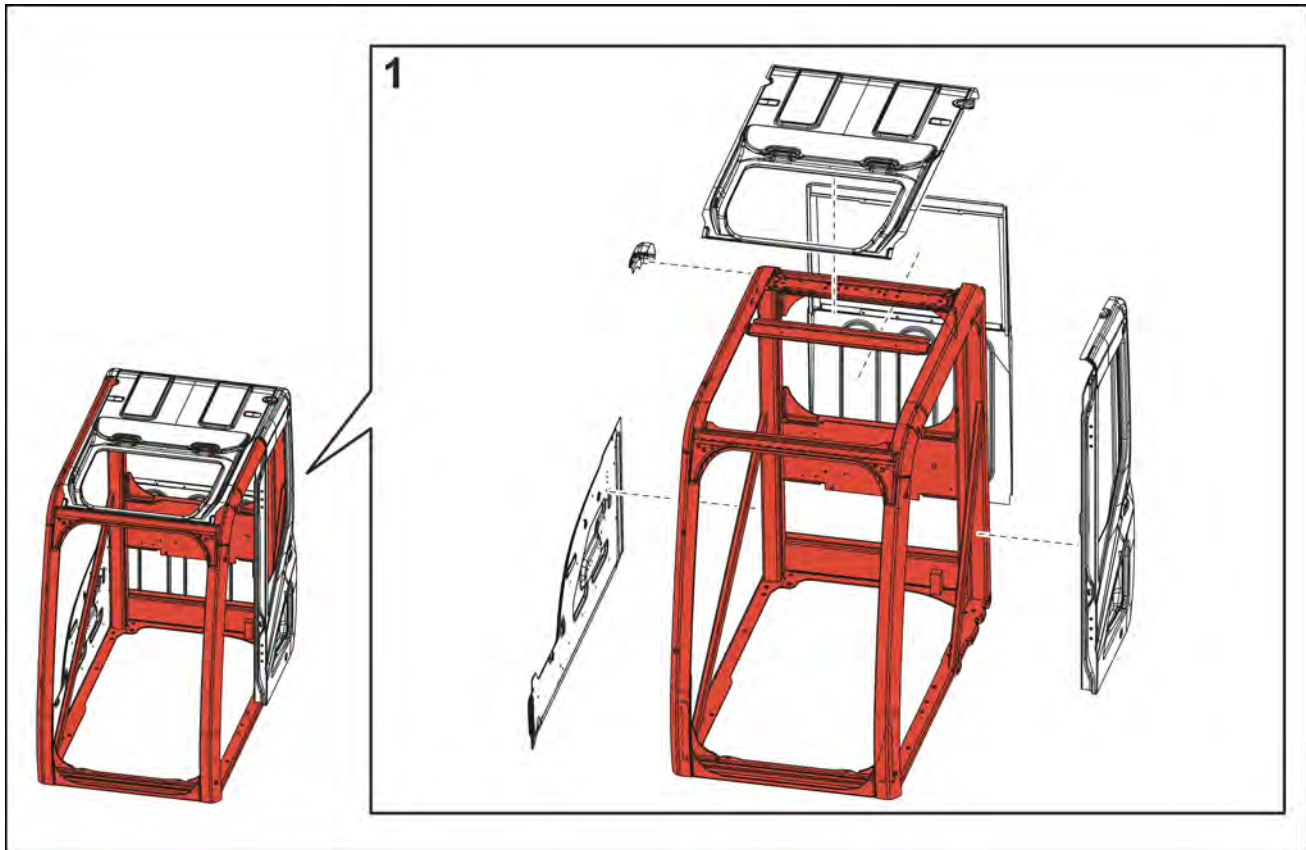

SMIL14CEX2002FA 3

---

## Safety rules - Ecology and the environment

Soil, air, and water quality is important for all industries and life in general. When legislation does not yet rule the treatment of some of the substances that advanced technology requires, sound judgment should govern the use and disposal of products of a chemical and petrochemical nature.

Familiarize yourself with the relative legislation applicable to your country, and make sure that you understand this legislation. Where no legislation exists, obtain information from suppliers of oils, filters, batteries, fuels, anti-freeze, cleaning agents, etc., with regard to the effect of these substances on man and nature and how to safely store, use, and dispose of these substances.

### Helpful hints

- Avoid the use of cans or other inappropriate pressurized fuel delivery systems to fill tanks. Such delivery systems may cause considerable spillage.
- In general, avoid skin contact with all fuels, oils, acids, solvents, etc. Most of these products contain substances that may be harmful to your health.
- Modern oils contain additives. Do not burn contaminated fuels and or waste oils in ordinary heating systems.
- Avoid spillage when you drain fluids such as used engine coolant mixtures, engine oil, hydraulic fluid, brake fluid, etc. Do not mix drained brake fluids or fuels with lubricants. Store all drained fluids safely until you can dispose of the fluids in a proper way that complies with all local legislation and available resources.
- Do not allow coolant mixtures to get into the soil. Collect and dispose of coolant mixtures properly.
- The air-conditioning system contains gases that should not be released into the atmosphere. Consult an air-conditioning specialist or use a special extractor to recharge the system properly.
- Repair any leaks or defects in the engine cooling system or hydraulic system immediately.
- Do not increase the pressure in a pressurized circuit as this may lead to a component failure.
- Protect hoses during welding. Penetrating weld splatter may burn a hole or weaken hoses, allowing the loss of oils, coolant, etc.

### Battery recycling

Batteries and electric accumulators contain several substances that can have a harmful effect on the environment if the batteries are not properly recycled after use. Improper disposal of batteries can contaminate the soil, groundwater, and waterways. CASE CONSTRUCTION strongly recommends that you return all used batteries to a CASE CONSTRUCTION dealer, who will dispose of the used batteries or recycle the used batteries properly. In some countries, this is a legal requirement.



### Mandatory battery recycling

**NOTE:** The following requirements are mandatory in Brazil.

Batteries are made of lead plates and a sulfuric acid solution. Because batteries contain heavy metals such as lead, CONAMA Resolution 401/2008 requires you to return all used batteries to the battery dealer when you replace any batteries. Do not dispose of batteries in your household garbage.

Points of sale are obliged to:

- Accept the return of your used batteries
- Store the returned batteries in a suitable location
- Send the returned batteries to the battery manufacturer for recycling

## Torque – Bolt and nut

- Tighten alternating between left and right and top and bottom so that uniform tightening force is applied.

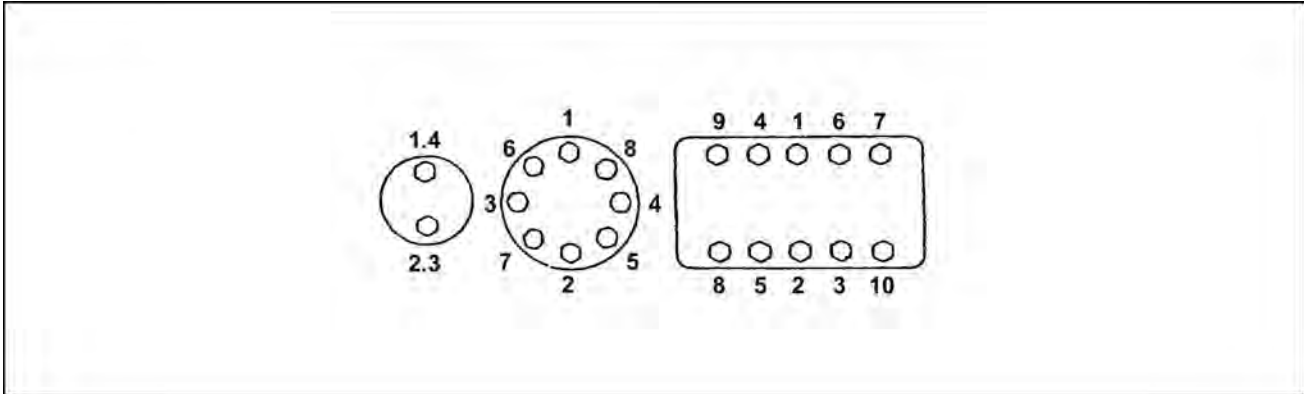

LPIL12CX00005EA 1

- If **LOCTITE®** was used on a removed bolt (there is something white sticking to the bolt when it is removed), clean the old **LOCTITE®** off with cleaning fluid, dry the bolt, then apply 2 - 3 drops of **LOCTITE®** to the thread section of the bolt.

### Torque table

Bolt nominal diameter (size)		M6	M8	M10	M12	M14	M16	M18	M20
Hexagon bolt	Wrench	10 mm	13 mm	17 mm	19 mm	22 mm	24 mm	27 mm	30 mm
	Tightening torque	6.9 N·m (5.089 lb ft)	19.6 N·m (14.456 lb ft)	39.2 N·m (28.912 lb ft)	58.8 N·m (43.369 lb ft)	98.1 N·m (72.355 lb ft)	156.9 N·m (115.72 m (144.63 3 lb ft)	196.1 N·m (144.63 6 lb ft)	294.2 N·m (216.99 1 lb ft)
Hexagon socket head bolt	Wrench	5 mm	6 mm	8 mm	10 mm	12 mm	14 mm	14 mm	17 mm
	Tightening torque	8.8 N·m (6.491 lb ft)	21.6 N·m (15.931 lb ft)	42.1 N·m (31.051 lb ft)	78.5 N·m (57.899 lb ft)	117.7 N·m (86.811 lb ft)	176.5 N·m (130.18 0 lb ft)	245.2 N·m (180.85 0 lb ft)	343.2 N·m (253.13 1 lb ft)

## Torque - Special torque setting

Code	Retightening location		Bolt nominal diameter	Wrench	Tightening torque
1*	Travel motor		M16	24 mm	267 - 312 N·m (196.93 - 230.12 lb ft)
2*	Drive sprocket		M16	24 mm	267 - 312 N·m (196.93 - 230.12 lb ft)
3*	Take-up roller		M16	24 mm	267 - 312 N·m (196.93 - 230.12 lb ft)
4*	Upper roller		M20	30 mm	521 - 608 N·m (384.27 - 448.44 lb ft)
5*	Lower roller		M18	27 mm	371 - 432 N·m (273.64 - 318.63 lb ft)
6*	Track guard		M18	27 mm	400 - 462 N·m (295.02 - 340.75 lb ft)
7	Shoe		M20	30 mm	250 - 350 N·m (184.39 - 258.15 lb ft)
8	Counterweight		M33	50 mm	1950 - 2156 N·m (1438.25 - 1590.18 lb ft)
9*	Turntable bearing		M24	36 mm	784 - 914 N·m (578.25 - 674.13 lb ft)
10*	Swing unit		M24	36 mm	784 - 914 N·m (578.25 - 674.13 lb ft)
11*	Engine	Mount	M16	24 mm	264.9 - 313.9 N·m (195.38 - 231.52 lb ft)
12*		Front bracket	M10	17 mm	63.8 - 73.6 N·m (47.06 - 54.28 lb ft)
13*		Rear bracket	M16	24 mm	205.9 - 247.1 N·m (151.86 - 182.25 lb ft)
14*	Radiator		M16	24 mm	147.2 - 176.6 N·m (108.57 - 130.25 lb ft)
15*	Hydraulic pump	Pump	M20	17 mm hexagon socket head	367 - 496 N·m (270.69 - 365.83 lb ft)
16*	Hydraulic oil tank		M16	24 mm	232.4 - 276 N·m (171.41 - 203.57 lb ft)
17*	Fuel tank		M16	24 mm	232.4 - 276 N·m (171.41 - 203.57 lb ft)
18*	Control valve		M16	24 mm	267 - 312 N·m (196.93 - 230.12 lb ft)
19*	Center	Lock bar	M12	19 mm	88.3 - 107 N·m (65.13 - 78.92 lb ft)
20*	Joint	Joint	M12	19 mm	109 - 127 N·m (80.39 - 93.67 lb ft)
21	Cab		M16	24 mm	149 - 173 N·m (109.90 - 127.60 lb ft)
22	Battery		M10	17 mm	19.6 - 29.4 N·m (14.46 - 21.68 lb ft)

**NOTE:** Make sure to apply **LOCTITE® 262™** or equivalent to the locations with the \* mark, and tighten according to the specified torque.

INTRODUCTION

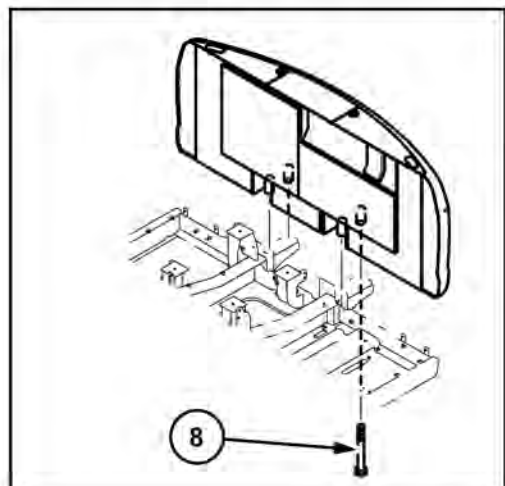
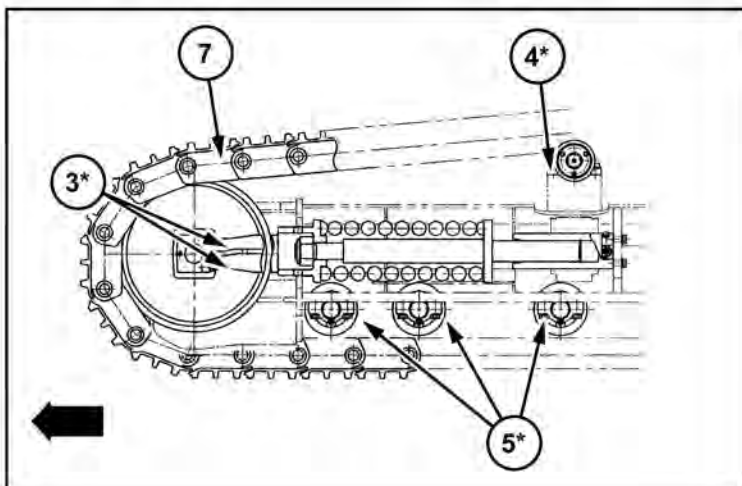
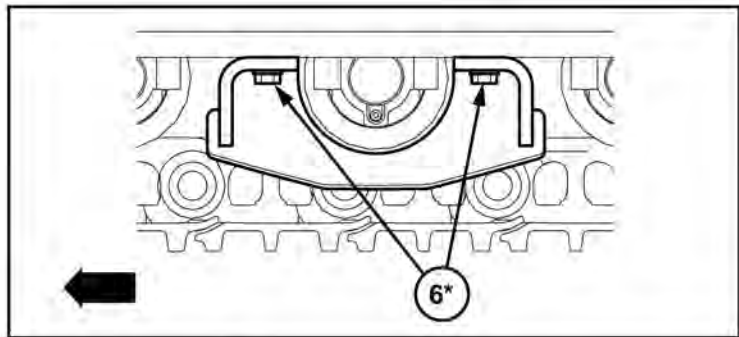
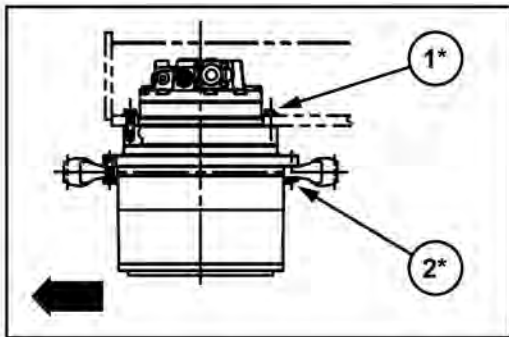
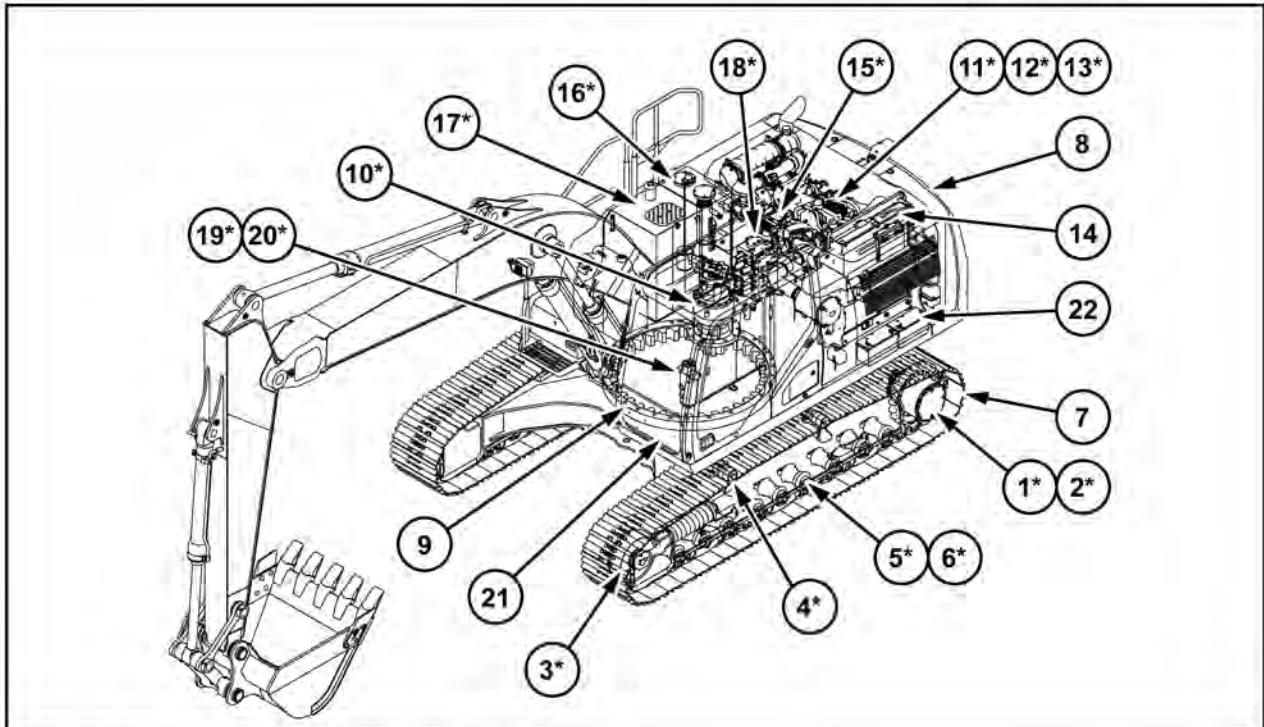

SMIL14CEX6655HB 1

INTRODUCTION

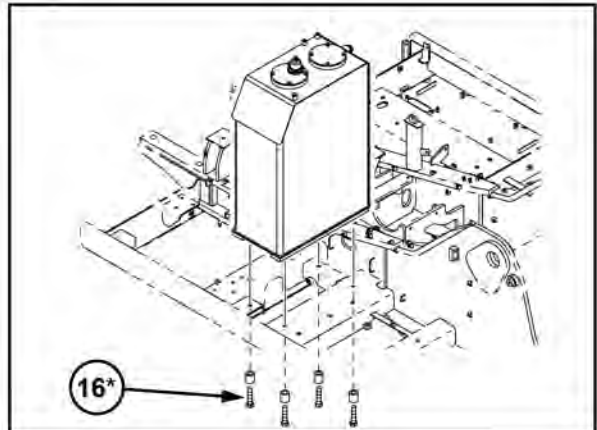
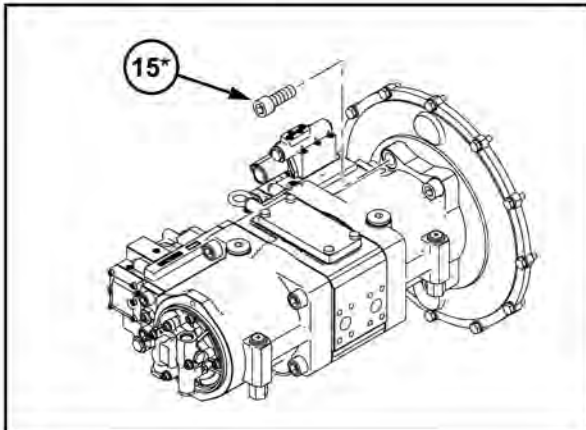
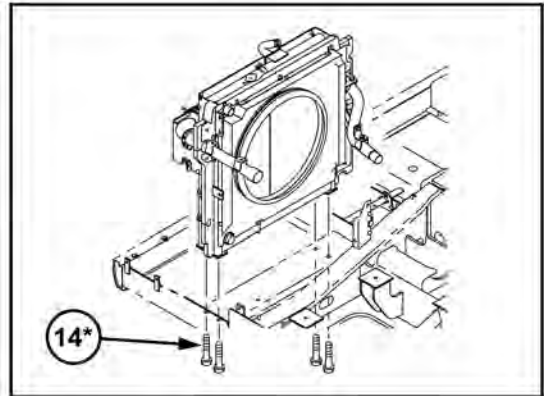
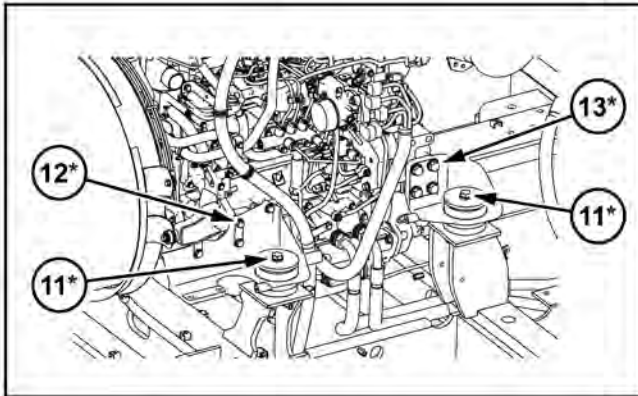
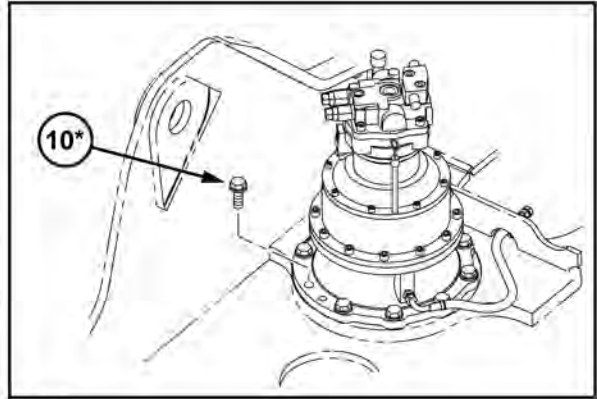
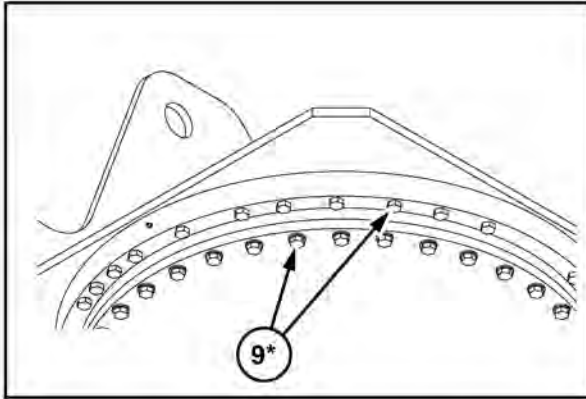

SML14CEX6657GB 2

# INTRODUCTION

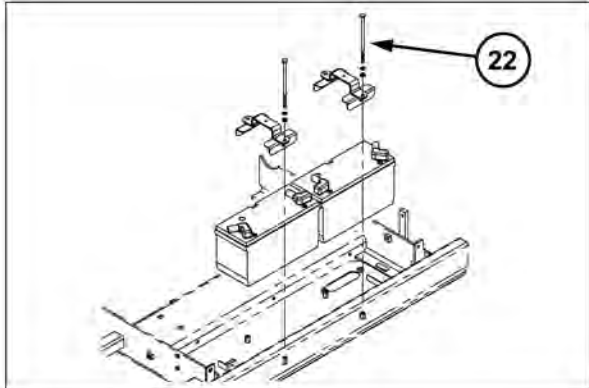
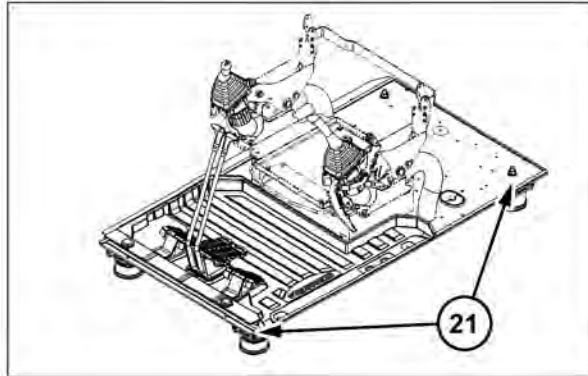
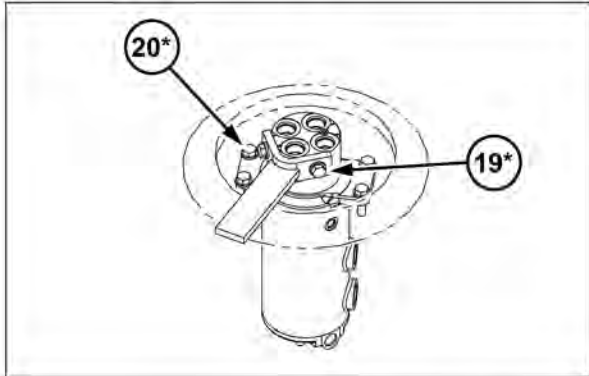
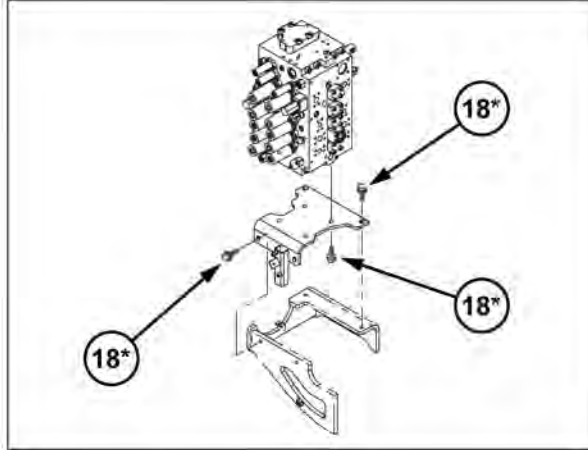
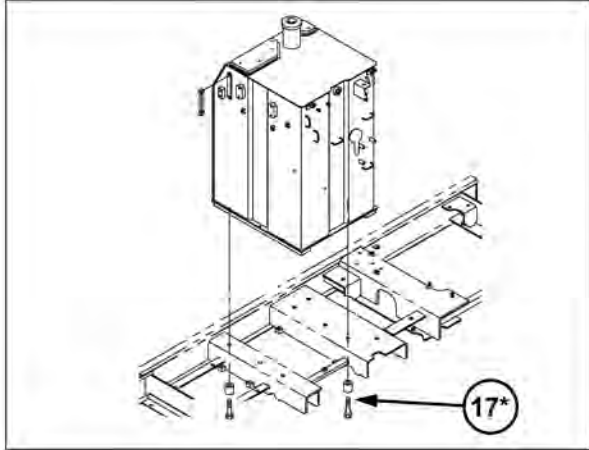

SMIL14CEX6656GB 3

---

## Basic instructions - Shop and assembly

### Shimming

For each adjustment operation, select adjusting shims and measure the adjusting shims individually using a micrometer, then add up the recorded values. Do not rely on measuring the entire shimming set, which may be incorrect, or the rated value shown on each shim.

### Rotating shaft seals

For correct rotating shaft seal installation, proceed as follows:

1. Before assembly, allow the seal to soak in the oil it will be sealing for at least thirty minutes.
2. Thoroughly clean the shaft and check that the working surface on the shaft is not damaged.
3. Position the sealing lip facing the fluid.

**NOTE:** *With hydrodynamic lips, take into consideration the shaft rotation direction and position the grooves so that they will move the fluid towards the inner side of the seal.*

4. Coat the sealing lip with a thin layer of lubricant (use oil rather than grease). Fill the gap between the sealing lip and the dust lip on double lip seals with grease.
5. Insert the seal in its seat and press down using a flat punch or seal installation tool. Do not tap the seal with a hammer or mallet.
6. While you insert the seal, check that the seal is perpendicular to the seat. When the seal settles, make sure that the seal makes contact with the thrust element, if required.
7. To prevent damage to the seal lip on the shaft, position a protective guard during installation operations.

### O-ring seals

Lubricate the O-ring seals before you insert them in the seats. This will prevent the O-ring seals from overturning and twisting, which would jeopardize sealing efficiency.

### Sealing compounds

Apply a sealing compound on the mating surfaces when specified by the procedure. Before you apply the sealing compound, prepare the surfaces as directed by the product container.

### Spare parts

Only use CNH Original Parts or CASE CONSTRUCTION Original Parts.

Only genuine spare parts guarantee the same quality, duration, and safety as original parts, as they are the same parts that are assembled during standard production. Only CNH Original Parts or CASE CONSTRUCTION Original Parts can offer this guarantee.

When ordering spare parts, always provide the following information:

- Machine model (commercial name) and Product Identification Number (PIN)
- Part number of the ordered part, which can be found in the parts catalog



---

## Protecting the electronic and/or electrical systems during charging and welding

To avoid damage to the electronic and/or electrical systems, always observe the following practices:

1. Never make or break any of the charging circuit connections when the engine is running, including the battery connections.
2. Never short any of the charging components to ground.
3. Always disconnect the ground cable from the battery before arc welding on the machine or on any machine attachment.
  - Position the welder ground clamp as close to the welding area as possible.
  - If you weld in close proximity to a computer module, then you should remove the module from the machine.
  - Never allow welding cables to lie on, near, or across any electrical wiring or electronic component while you weld.
4. Always disconnect the negative cable from the battery when charging the battery in the machine with a battery charger.

**NOTICE:** *If you must weld on the unit, you must disconnect the battery ground cable from the machine battery. The electronic monitoring system and charging system will be damaged if this is not done.*

5. Remove the battery ground cable. Reconnect the cable when you complete welding.

### WARNING

**Battery acid causes burns. Batteries contain sulfuric acid.**

**Avoid contact with skin, eyes or clothing. Antidote (external): Flush with water. Antidote (eyes): flush with water for 15 minutes and seek medical attention immediately. Antidote (internal): Drink large quantities of water or milk. Do not induce vomiting. Seek medical attention immediately. Failure to comply could result in death or serious injury.**

W0111A

## Special tools

The special tools that CASE CONSTRUCTION suggests and illustrate in this manual have been specifically researched and designed for use with CASE CONSTRUCTION machines. The special tools are essential for reliable repair operations. The special tools are accurately built and rigorously tested to offer efficient and long-lasting operation.

By using these tools, repair personnel will benefit from:

- Operating in optimal technical conditions
- Obtaining the best results
- Saving time and effort
- Working in safe conditions

## Hydraulic contamination

Contamination in the hydraulic system is a major cause of the malfunction of hydraulic components. Contamination is any foreign material in the hydraulic oil.

Contamination can enter the hydraulic system in several ways:

- When you drain the oil or disconnect any line
- When you disassemble a component
- From normal wear of the hydraulic components
- From damaged seals or worn seals
- From a damaged component in the hydraulic system

All hydraulic systems operate with some contamination. The design of the components in this hydraulic system permits efficient operation with a small amount of contamination. An increase in this amount of contamination can cause problems in the hydraulic system.

The following list includes some of these problems:

- Cylinder rod seals that leak
- Control valve spools that do not return to neutral
- Movement of control valve spools is difficult
- Hydraulic oil that becomes too hot
- Pump gears, housing, and other parts that wear rapidly
- Relief valves or check valves held open by dirt
- Quick failure of components that have been repaired
- Slow cycle times are slow. The machine does not have enough power.

If your machine has any of these problems, check the hydraulic oil for contamination.

There are two types of contamination: microscopic and visible.

Microscopic contamination occurs when very fine particles of foreign material are suspended in the hydraulic oil. These particles are too small to see or feel. Microscopic contamination can be found by identification of the following problems or by testing in a laboratory.

Examples of problems caused by microscopic contamination:

- Cylinder rod seals that leak
- Control valve spools that do not return to neutral
- The hydraulic system has a high operating temperature

Visible contamination is foreign material that can be found by sight, touch, or odor. Visible contamination can cause a sudden failure of components.

Examples of problems caused by visible contamination:

- Particles of metal or dirt in the oil
- Air in the oil
- Dark or thick oil
- Oil with an odor of burned oil
- Water in the oil

If you find contamination, use a portable filter to clean the hydraulic system.

## General specification

### Engine

Type	Water-cooled, 4-cycle diesel, 4-cylinder in line, High pressure common rail system (electric control), Turbocharger with air cooled intercooler, SCR system	
Model	ISUZU AR-4HK1X	
Rated flywheel horse power		
	<b>SAE J1349, ISO 9249</b>	<b>119.3 kW (162.2 Hp) at 1800 RPM</b>
	<b>ISO 14396</b>	<b>124 kW (169 Hp) at 1800 RPM</b>
Piston displacement	<b>5193 cm<sup>3</sup> (317 in<sup>3</sup>)</b>	
Maximum torque		
	<b>SAE J1349, ISO 9249</b>	<b>620 N·m (457 lb ft) at 1600 RPM</b>
	<b>ISO 14396</b>	<b>636 N·m (469 lb ft) at 1600 RPM</b>
Bore and stroke	<b>115 - 125 mm (4.53 - 4.92 in)</b>	
Voltage	<b>24 V</b>	
Alternator	<b>50 A</b>	
Starter	<b>24 V 5.0 kW</b>	

### Hydraulic system

Main pumps	2 variable displacement axial piston pumps with regulating system	
	Max. oil flow	<b>2 × 211 L (55.7 US gal) at 1800 RPM</b>
	Working circuit pressure	Boom/Arm/Bucket
		Swing circuit
		Travel circuit
		<b>34.3 MPa (4975 psi)</b>
	<b>37.3 MPa (5410 psi) with auto power up</b>	
	<b>29.4 MPa (4265 psi)</b>	
	<b>34.3 MPa (4975 psi)</b>	
Pilot pump	1 gear pump	
	Max. oil flow	<b>18 L (4.8 US gal)</b>
	Working circuit pressure	<b>3.9 MPa (566 psi)</b>
Control valves	With Boom/Arm holding valve	
	One 4-spool valve for Right track travel, Bucket, Boom and Arm acceleration	
	One 5-spool valve for Left track travel, Auxiliary, Swing, Boom acceleration and Arm	
Swing device		
	Motor	Fixed displacement axial piston motor
	Brake	Mechanical disc brake
	Final drive	Planetary gear reduction
	Turn table bearing	Ball bearing type with internal gear
	Maximum swing speed	<b>11.5 RPM</b>
	Swing torque	<b>64000 N·m (47204 lb ft)</b>
Cylinders	NO. of cylinders – bore X Rod diameter X Stroke	
	Boom	<b>2 x Ø 120 mm (4.724 in) - Ø 85 mm (3.346 in) - 1255 mm (49.409 in)</b>
	Arm	<b>1 x Ø 140 mm (5.512 in) - Ø 100 mm (3.937 in) - 1460 mm (57.480 in)</b>
	Bucket	<b>1 x Ø 120 mm (4.724 in) - Ø 85 mm (3.346 in) - 1010 mm (39.764 in)</b>
Cooling system		
	Fan	<b>Ø 650 mm (25.6 in) with 7-blades</b>
	Radiator capacity	<b>105.9 kW</b>
		fin type
		Corrugated fin (wavy type)
		fin space
		<b>1.75 mm (0.06890 in)</b>
	Long life coolant	Coolant <b>55 %</b> , Water <b>45 %</b>
	Oil cooler capacity	<b>54.1 kW</b>
		fin type
		Corrugated fin (wavy type)

INTRODUCTION

	fin space	<b>1.75 mm (0.06890 in)</b>
Intercooler capacity		<b>16.7 kW</b>
	fin type	Straight fin
	fin space	<b>1.75 mm (0.06890 in)</b>
Fuel cooler capacity		<b>1.3 kW</b>
	fin type	Corrugated fin (wavy type)
	fin space	<b>2.0 mm (0.0787 in)</b>
Filters		
Suction filter		105 µm
Return filter		6 µm
Pilot line filter		8 µm

**Hydraulic controls**

Boom/Arm/Bucket/Swing	Pilot pressure control system (ISO control pattern)
Travel	Pilot pressure control system
Work mode select	SP - mode
	H - mode
	Auto - mode
Travel mode select	2-speed travel
Attachment cushion control	
Hydraulic lock (gate lock, left side tilt console)	

**Electrical system**

Engine control		
	Dial type throttle control	
	One touch idle / Auto deceleration / Auto idle shutdown system	
	Emergency stop	
Monitor system		
	Message display (Caution, condition, etc.)	
	Work mode display (SP, H, Auto)	
	Machine condition (Power boost, etc.)	
	Alarm display and buzzer	
	Water temperature	
	Hydraulic oil temperature	
	Fuel level	
	Diagnosis system	
	Rear view camera image	
	Urea water level	
Wire harness		
	Waterproof type connector	
Safety		
	Double horn	
Battery	2 X 12 V 92 A·h/5HR	
Lights		
Working light	Upper	24 V 70 W X 1
	Boom	24 V 70 W X 1
	Cab	24 V 70 W X 2
Operator's cab room		24 V 70 W X 1

## Operator environment

Operator's cab		
	Smooth and round shape design cab, fabricated by press work	
	Safety glass for all windows	
	Shock-less cab suspension by 4-point fluid mounting	
	Sliding front window with auto lock	
	Built-in type full-color LCD monitor display	
	Membrane switch on monitor display	
	Windshield wiper & washer	
	Floor mat	
	Polycarbonate roof hatch & Sun shade	
	Auto air-conditioner	
	Rain deflector	
	Sun visor	
	Roll-over protective structure (ROPS)	
	Top guard OPG level 1 (in CAB structure)	
	Top guard OPG level 2 (additional guard)	
Operator's seat		
	Low frequency air suspension with air springs and double acting hydraulic damper. (Achieves ISO7096 in category EM6)	
	With following features	
	Manual weight adjustment	Backrest angle adjustment
	Seat height adjustment	Adjustable pivoting armrests linked to consoles
	Adjustable headrest	Retractable seat belt
	Adjustable lumbar support	Control consoles adjust independently of seat
Others		
	Rear view mirror (Cab side & Right side)	
	Rear view Camera	

## Undercarriage

Travel motor	Variable displacement axial piston motor	
Brake	Mechanical disc brake	
Hydraulic service brake	Brake valve	
Final drive	Planetary gear reduction	
Travel speeds	High	<b>5.6 km/h (3.5 mph)</b> (Automatic travel speed shifting)
	Low	<b>3.4 km/h (2.1 mph)</b>
Drawbar pull	<b>188 kN (42264 lb)</b>	
Number of carrier rollers (each side)	2	
Number of track rollers (each side)	8	
Number of shoes (each side)	49	
Type of shoe	Triple grouser shoe	
Link pitch	<b>190 mm (7.480 in)</b>	
Width of shoe	<b>600 mm (23.622 in)</b> (S.T.D)	
Grade-ability	<b>70 % ( 35 ° )</b>	

**Mass**

Operating mass	<b>21700 kg (47840 lb)</b>
with <b>2.40 m (7.87 ft)</b> Arm, <b>1.0 m<sup>3</sup></b> Bucket, <b>600 mm (23.622 in)</b> grouser shoe, operator, lubricant, coolant and full fuel tank, and top guard OPG level 2	
Shipping mass	<b>20600 kg (45415 lb)</b>
Operating mass - (operator mass [ <b>75 kg (165.35 lb)</b> ] + <b>90 %</b> of fuel mass + bucket mass [ <b>698 kg (1538.83 lb)</b> ]	
Counter weight mass	<b>3920 kg (8642 lb)</b>
Ground pressure	<b>0.045 MPa (6.527 psi)</b>
with <b>2.40 m (7.87 ft)</b> Arm, <b>1.0 m<sup>3</sup></b> Bucket, <b>600 mm (23.622 in)</b> grouser shoe	

**Digging force (with 1.0 m<sup>3</sup> bucket) ( ISO 6015)**

	<b>2.40 m (7.87 ft) Arm</b>	<b>1.91 m (6.27 ft) Arm</b>	<b>2.94 m (9.65 ft) Arm</b>
Arm digging force	<b>123 kN (27652 lb)</b>	<b>142 kN (31923 lb)</b>	<b>103 kN (23155 lb)</b>
With auto power up	<b>133 kN (29900 lb)</b>	<b>154 kN (34621 lb)</b>	<b>112 kN (25179 lb)</b>
Bucket digging force	<b>142 kN (31923 lb)</b>	<b>142 kN (31923 lb)</b>	<b>142 kN (31923 lb)</b>
With auto power up	<b>154 kN (34621 lb)</b>	<b>154 kN (34621 lb)</b>	<b>154 kN (34621 lb)</b>

**Dimensions**

	<b>2.40 m (7.87 ft) Arm</b>	<b>1.91 m (6.27 ft) Arm</b>	<b>2.94 m (9.65 ft) Arm</b>
Overall length (without attachment)	<b>5000 mm (196.850 in)</b>	<b>5000 mm (196.850 in)</b>	<b>5000 mm (196.850 in)</b>
Overall length (with attachment)	<b>9510 mm (374.409 in)</b>	<b>9540 mm (375.591 in)</b>	<b>9430 mm (371.260 in)</b>
Overall height (to top of boom)	<b>3190 mm (125.591 in)</b>	<b>3100 mm (122.047 in)</b>	<b>2980 mm (117.323 in)</b>
Overall height (to top of Cab)	<b>3070 mm (120.866 in)</b>	<b>3070 mm (120.866 in)</b>	<b>3070 mm (120.866 in)</b>
Overall height (to top of guardrail)	<b>3280 mm (129.134 in)</b>	<b>3280 mm (129.134 in)</b>	<b>3280 mm (129.134 in)</b>
Upper structure overall width	<b>2770 mm (109.055 in)</b>	<b>2770 mm (109.055 in)</b>	<b>2770 mm (109.055 in)</b>
Swing (rear end) radius	<b>2790 mm (109.843 in)</b>	<b>2790 mm (109.843 in)</b>	<b>2790 mm (109.843 in)</b>
Clearance height under upper structure	<b>1050 mm (41.339 in)</b>	<b>1050 mm (41.339 in)</b>	<b>1050 mm (41.339 in)</b>
Minimum ground clearance	<b>440 mm (17.323 in)</b>	<b>440 mm (17.323 in)</b>	<b>440 mm (17.323 in)</b>
Wheel base (Center to center of wheels)	<b>3660 mm (144.094 in)</b>	<b>3660 mm (144.094 in)</b>	<b>3660 mm (144.094 in)</b>
Crawler overall length	<b>4470 mm (175.984 in)</b>	<b>4470 mm (175.984 in)</b>	<b>4470 mm (175.984 in)</b>
Track gauge	<b>2390 mm (94.094 in)</b>	<b>2390 mm (94.094 in)</b>	<b>2390 mm (94.094 in)</b>
Undercarriage overall width [with <b>600 mm (23.622 in)</b> shoes]	<b>2990 mm (117.717 in)</b>	<b>2990 mm (117.717 in)</b>	<b>2990 mm (117.717 in)</b>
Crawler tracks height	<b>920 mm (36.220 in)</b>	<b>920 mm (36.220 in)</b>	<b>920 mm (36.220 in)</b>

**Thanks for your reading.**

**Please click here to download complete manual instantly.**

**And can also choose other manuals.**

**Feel free --->write to me with any questions.**

**Our service email:**

**manuals007@hotmail.com**